

# **Mathematics of the Great Pyramid**

**In the shadow of the pyramid**



**Wim van Es**

**Mathematics of the Great Pyramid**  
**In the shadow of the pyramid**

**Wim van Es**

## **Mathematics of the Great Pyramid - In the shadow of the pyramid**

**Wim van Es**

**© 2022 Wim van Es**

[info@wim-vanes.nl](mailto:info@wim-vanes.nl)

CIP - data Royal Library, The Hague

ISBN: 978-90-9036723-1

NUR: 921

Keyword: Fundamental Mathematics.

© No part of this book may reproduce in any form, be print, photoprint, microfilm, or any other means without written permission from the publisher.

# Mathematics of the Great Pyramid

In the shadow of the pyramid



**Wim van Es**

## Preface.



This book briefly describes how the author Wim van Es acquired his geometric knowledge and how he further developed this geometric knowledge.

The book describes the entire geometric knowledge of the Great Pyramid on the Giza plateau in Egypt. It is one of a kind because everything is new. None of what is described is known in mathematics until 2022.

This book is an extensive summary of the previously published 10 Dutch study booklets. It contains new knowledge that was not known before, such as a new way to create a golden spiral, based on an equilateral triangle (pyramid) and much more.

Everything in this book may be used if the name of the author WvEs is mentioned.



Wim van Es

October 2022

## Introduction.

It started with the solar eclipse on Wednesday, August 11, 1999. Around noon, the Moon passed in front of the Sun. I stood with many others watching how it would all manifest. It was as if everything stopped for a moment. Wonderful, you would say, were it not for the fact that this moment was a reason for me to take a closer look at the phenomena we had learned at school. After the solar eclipse, which lasted no longer than 5 minutes, everyone went back to business as usual. Something happened to me unexpectedly and also unconsciously, in hindsight. How could a moon shadow pass over the Earth from West to East, if the Earth rotates faster than the Moon on its own imaginary axis? The moon shadow should then logically move from East to West. It was stated that the Moon moved past the Earth from right to left (node), making it logical that the Moon's shadow moved from West to East. In that case it is indicated that the Moon is moving faster than the Earth. If the speed of the Earth when it rotates is 1,600 km per hour, then the Moon would move past us with say (approximately) 2,400 km per hour. How could that be I wondered? The Moon (A) orbits the Earth once every 28 days.

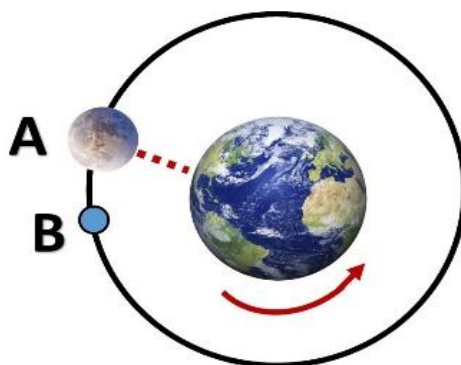

When the Moon arrives at position B (suppose this takes a day) then the Earth has rotated once (position A).

How could the Moon pass the Earth (in speed) I wondered? Considering the proposition that during a solar eclipse the Moon passes by the Earth and slides in between the Earth and the Sun, seen from right to left.

It seemed logical to me that this couldn't be possible. And that if there were moon shadow it would have to be in the opposite direction of the Earth's rotation. In this case from East to West.

What do we know? The Moon rises daily in the East and sets in the West. And that since time immemorial. Isn't it striking that in the evening/night of August 10-11, 1999, the Moon still rises in the East and sets in the West, and then goes faster than the Earth, during the day on August 11 (7 hours later) from West to East, and then rise again in the East in the evening/night of 11 to 12 August (12 hours later) and set in the West?

While people in my environment looked at the phenomenon (total solar eclipse) in a light state of euphoria, the opposite arose for me. I became confused and wondered what was I really seeing?

Did I now see the Moon slide past and between the Earth and the Sun or did I see the Earth slide past the Moon in the opposite direction? In that case, the moon shadow from West to East would be explainable.

This phenomenon brought me to where I am now. I started to do more research into the phenomena we have assumed as humans. I was going to test them using logic and simple equations.

I always asked myself the question: 'can it be different than what we think and have assumed?' What is reality and what is optical illusion? Can we judge for accuracy immensely large distances from a small Earth?

The same thing happened in 2004. It was announced worldwide that on Tuesday, June 8, 2004, the planet Venus will pass in front of the Sun as seen from Earth. Also called transit of Venus.

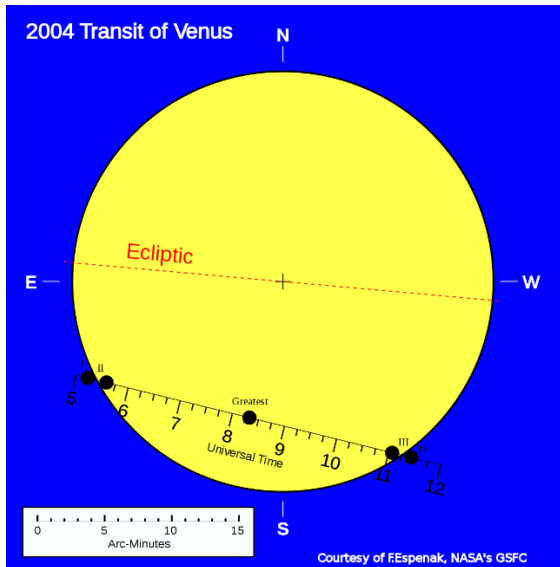

Pictures from Wikipedia

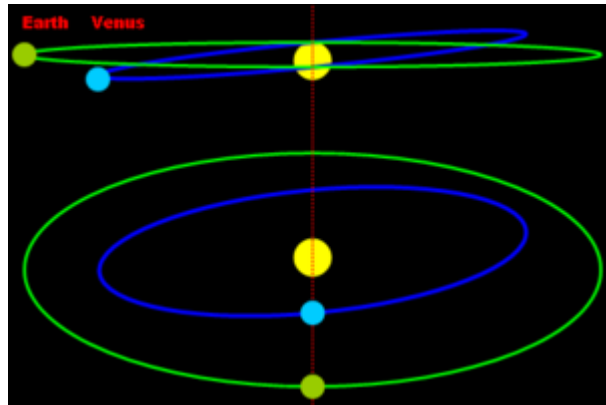

For many people again a spectacular phenomenon to watch. It would start at 5:13 am and end at 11:56 am. So super accurate. The transit of Venus would take 6 hours and 43 minutes, viewed from Earth from left to right. The next day everyone went back to business as usual. However, I didn't understand something.

Scientifically we state on Earth that the orbital period of the Earth around the Sun lasts 365 days and the orbital period of Venus around the Sun lasts 224 days. If you look closely at the pictures, you will see something remarkable. You see the Sun. And so, you see a flat yellow surface. We see as people flat.

However, the Sun is a sphere, and you can't see it. So, if I were to draw a line (Ecliptic) from E (East) to W (West), then you could say in a flat observation that the line is, for example, 10 cm. However, it is a sphere and that means that the line you see plane is actually  $10 \times 3.14$  divided by 2, 15.7 cm.



So, if we say that Venus revolves around the Sun in 224 days, then you see at the transit of Venus that Venus completes a semicircle (half an orbit) around the Sun. Under normal circumstances, it takes 112 days.

How striking is it then to say that Venus takes only 6 hours and 43 minutes on Tuesday, June 8, 2004?

You should ask yourself to what extent you see the real reality?

What if Venus doesn't do what you think you see at all? What if Venus quietly completes its orbit around the Sun and Earth moves in the opposite direction in accelerated attraction (like the 1999 solar eclipse)?

And, as always, people go over to the order of the day, and nobody talks about it anymore. Am I the only one in this world who questions this? What explanation do you give to the above if you don't think about it?

These phenomena and more aroused my curiosity and I set out to investigate. I started to study geometry.

I tried to understand and explain everything as simply as possible. No (technical jargon) use of language that no one understands. I thought of a quote that says: 'if you can't explain it simply, you often don't understand it yourself.'

This quote was the filter through which I examined everything.

It wasn't just geometry that captivated me. It was also the meaning and interpretation of the spoken word that interested me. For example: what is attraction? What does attracting mean and how do you attract something in practice?

Try it on and then learn what it means. What does it mean when two people attract each other, what exactly happens to force and resistance? Then project this learned into cosmic attraction. You will be amazed at what you will find out.

As a therapist and NLP trainer, I learned to read between the lines. How were stories told in ancient times in a society where superstitions were the order of the day? How did you gain insight into a subjectively written story from which a message had to be based? What was the meaning of symbolism and mythology? How do you transfer scientific cosmic knowledge to a 'child' (underdeveloped human being) who thinks that the Earth is flat, and the gods are willing on the one hand, or punish him?

This and more prompted me to put the knowledge I now have in writing.

At the same time, I delved into Egyptian mythology, which gave me many insights into the creation myth.

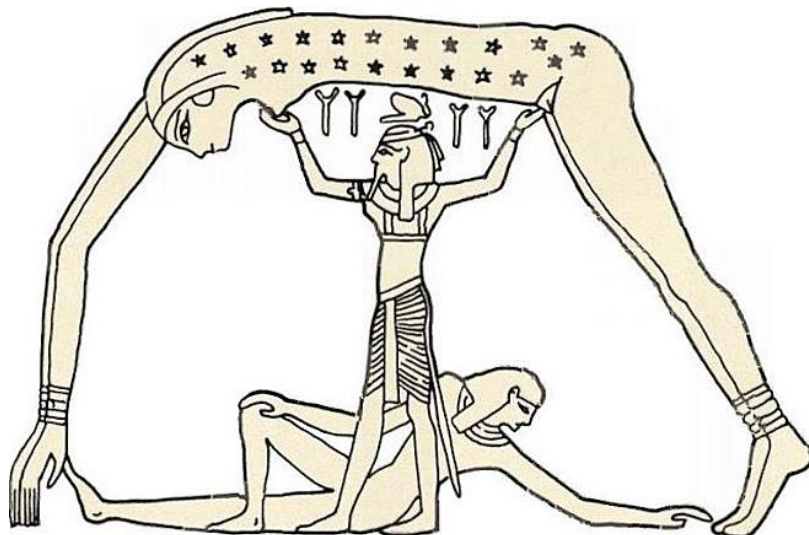

The Ancient Egyptian Creation Myth.

# Chapter 1

## The pyramid story.

In 2019, my geometric insights were strongly activated. The symbol of the 'golden' triangle used in some organizations gave me a new look at geometry. I saw how the Pyramid was formed from 4 'golden' equilateral triangles.

This brought me to my Pyramid research.

It has led me to write 10 small textbooks and as a conclusion now this complete work.

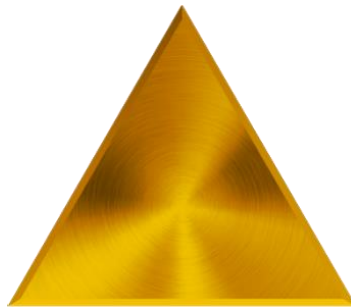

The 'golden' triangle is the symbol of an equilateral triangle. You can now give the symbol a personal meaning and you can determine the mathematical meaning of the equilateral triangle in architecture. In this book I therefore opt for the mathematical approach.

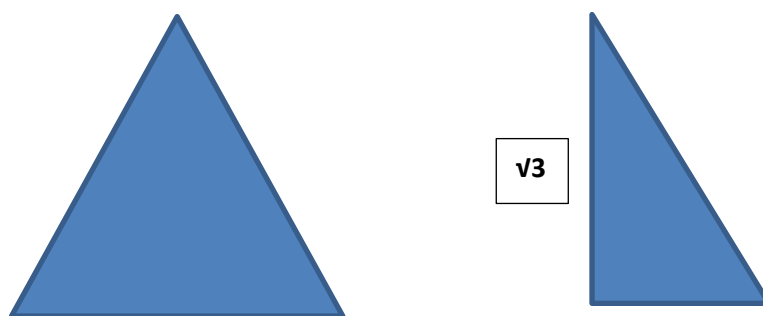

Figure 1

In figure 1 you see the equilateral triangle. It is a triangle with three angles of  $60^\circ$ . The right triangle next to it is therefore a derivative of the equilateral triangle. With the angles, respectively  $60^\circ$ ,  $30^\circ$  and  $90^\circ$ , it is in the ratio  $1:2:\sqrt{3}$  compared to the sides. This is the basic geometry.

If you now study what is known about these triangles and consult the internet, you will also discover what is not known about these triangles.

I am going to show you in this book what is not known.

### **The number 666.**

What is the meaning of 666.

*The italics below can be found on the internet.*

*There are mysterious numbers in the Bible. The most mysterious is still 666, the number of the beast. What is the symbolism of that number and who is the beast?*

*In a very mysterious passage, John writes: "Here comes wisdom. If you have understanding, calculate the number of the beast, for it is the number of a man. His number is 666."*

*According to mathematicians, 666 is special, because it is a so-called triangular number, and they are rare. For example, the number 6 is such a triangular number. You can form a nice triangle from one and if you add them together, you get 6:*

*1*

*11*

*111*

You can now connect everything from the Devil to the Antichrist. It just shows great ignorance and insufficient mathematical understanding about the number 666.

The number 666 is perfection.

It is the foundation of this book upon which all the mathematics I describe in this chapter is based. The number 666 represents a ratio of 6:6:6. It is linked to the triangle (a triangle number).

Now let's see how simple it can be.

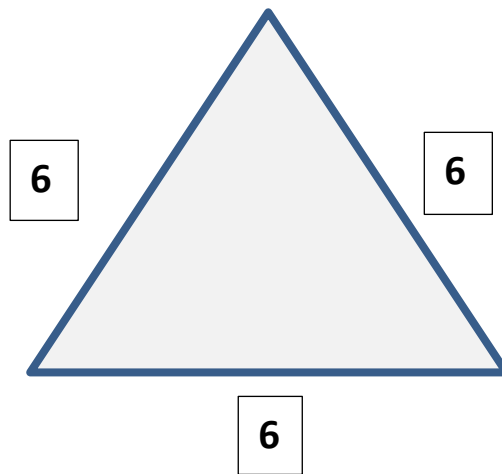

**Figure 2**

If we determine three sides of the equilateral triangle at 6, we have the perfect triangle relationship, see figure 2.

If we now work with this ratio and subject the equilateral triangle to further investigation, we get figure 3.

Figure 3 shows how the perfect triangle takes shape. The ratio 6:6:6 (6cm:6cm:6cm) taken as a starting point makes the ratio 60mm:60mm:60mm.

The number of degrees of this equilateral triangle are then in the ratio  $60^\circ:60^\circ:60^\circ$ . It couldn't be more perfect.

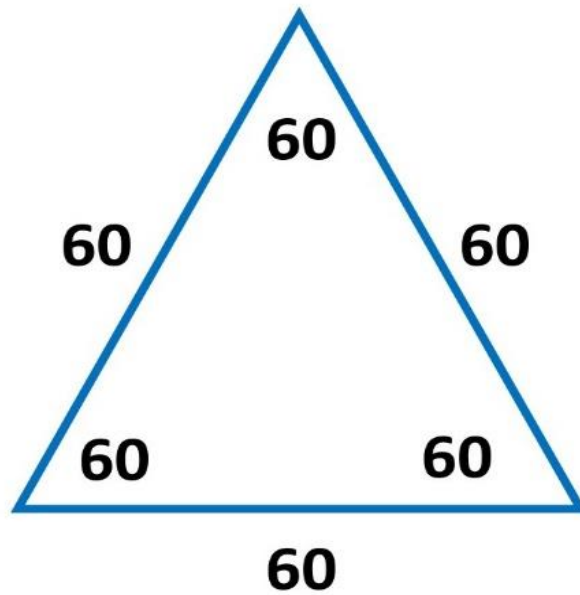

Figure 3

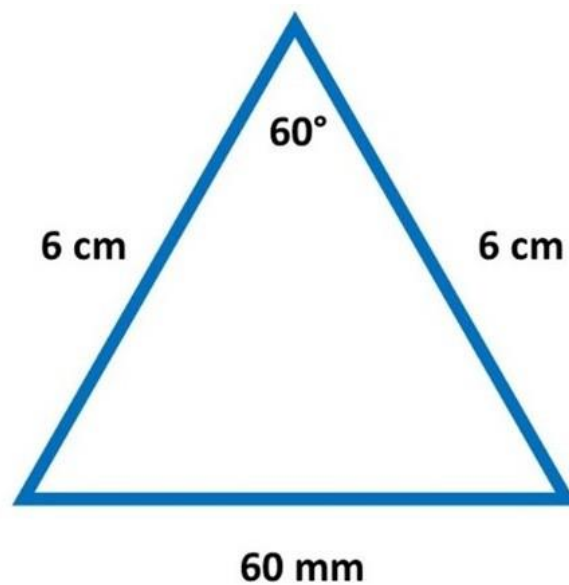

Figure 4

The triangle in figure 4 shows that if the sides of the triangle are equal to 6 cm or 60 mm, then the angle of 60 degrees is equal to the 60 mm on the opposite side.

If I now expand 18 mm on the opposite side of the triangle in figure 5, then I have an angle of 18°.

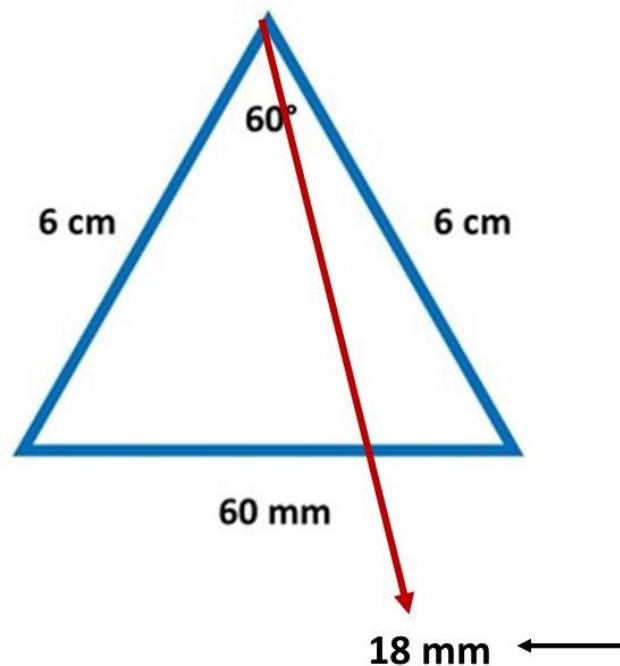

Figure 5

If I am now going to make the sides of the triangle larger, say 9 cm, then I will have to apply a ratio factor that reduces everything to 6 cm. In the case of figure 5 that is:  $(9/6=1.5) \times 1.8 = 2.7$  cm. In an equilateral triangle of 9 cm, you will have to expand 2.7 cm from right to left to get an angle of 18 degrees.

The ratio 6:6:6 (666) is essential in everything. Symbolically speaking, it is a "sacred" geometric number.

The equilateral triangle in the ratio 6:6:6 has much more value. With this ratio you can change the entire trigonometry that is used to this day 2022. You no longer need tables and calculators to determine (read) angles and sides according to the sine, cosine, and tangent method. You can calculate all angles and sides of an (arbitrary) triangle with the ratio 6:6:6.

What is still special about the equilateral triangle in the ratio 6:6:6? You can move the sides and make the opposite side of the angle smaller. If we make the triangle smaller so that it becomes an isosceles triangle whose apex angle is less than  $60^\circ$  and the isosceles sides are always 6 cm, then the baseline is equal to the angle in mm, figure 6.

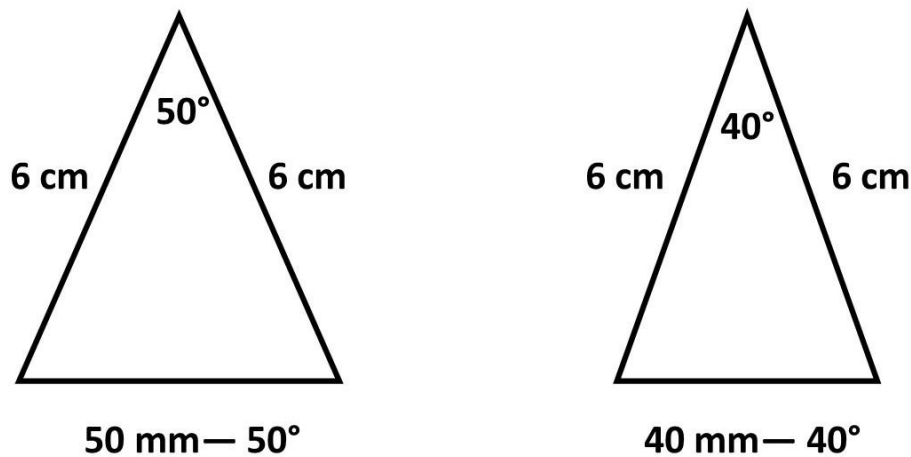

Figure 6

In figure 6 I have chosen measures in tens. It can also be any apex angle of, for example,  $53^\circ$  or  $47^\circ$  or  $34^\circ$ . As long as you keep the isosceles sides at 6 cm, the base side will be equal to the angle in mm. And it can be at an apex angle of  $29^\circ$  or  $20^\circ$  or  $15^\circ$ .

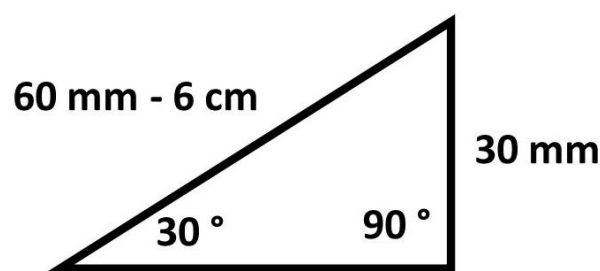

Figure 7

However, with these last measures we use the right triangle in figure 7. The apex angle is then below  $30^\circ$  and that is easier to do the calculations that I'm going to show you now.



With the triangles in figure 6 and 7 you change the whole current known trigonometry. Trigonometry is a branch of geometry that deals with the relationships between sides and angles in planar and spatial triangles.

A few years ago, I read a question from a math student. He asked if you could calculate the angles and sides of a right triangle without using the sine, cosine, and tangent table or the pre-programmed calculator. The answer was a clear no. I don't know if the student was happy with that. I'll show you now that it is possible.

Furthermore, I also show you that you can calculate the sides of any triangle (not a right triangle).

All you need is a knowledge of the triangles in figure 6 and 7.

I now show several examples, from easy to difficult.

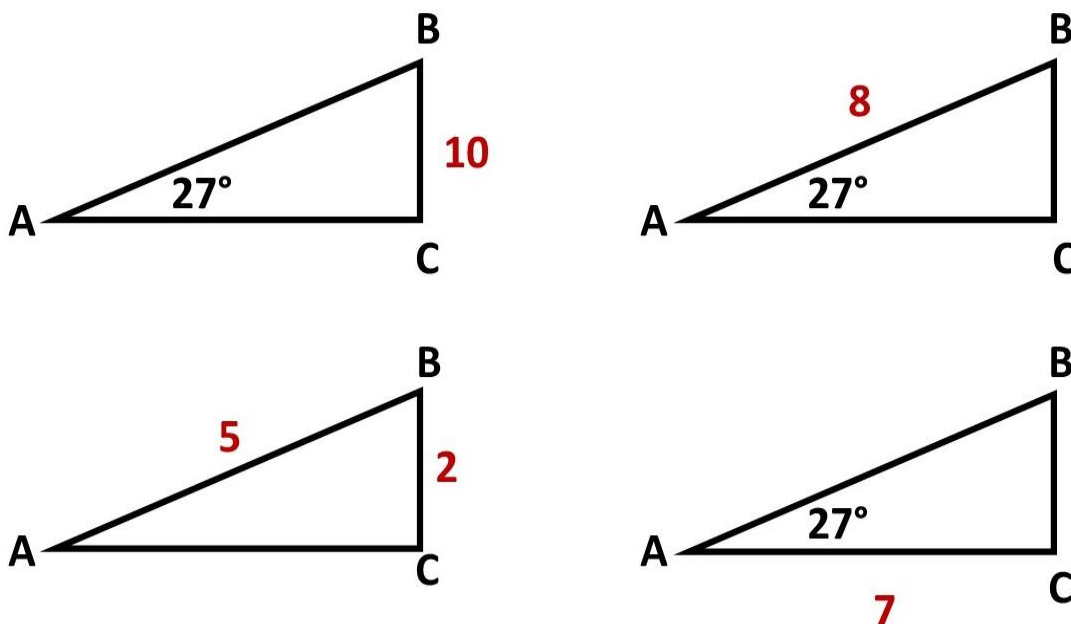

Figure 8

How do you calculate the sides and angles in figure 8?

For the sake of convenience and overview, I have set angle A at  $27^\circ$  for three triangles. So, this can be anything below  $30^\circ$ . The starting point should always be the smallest angle from which the calculations take place.

We start with **the first triangle** in figure 8. Angle A =  $27^\circ$  and side B-C = 10 cm. How big are sides A-B and A-C?

You know that if side A-B were 6 cm, then B-C would be 2.7 cm. However, B-C is 10 cm. That is  $(10/2.7)$  a factor of 3.7 higher. Side A-B is therefore factor 3.7 higher, is  $3.7 \times 6 = 22.2$  cm. Side A-C can then be calculated with  $A^2 + B^2 = C^2 = 19.8$  cm.

**The second triangle.** Angle A =  $27^\circ$  and side A-B = 8 cm. How big are sides A-C and B-C? Then the same again. If side A-B were 6 cm, B-C would be 2.7 cm. However, A-B is 8 cm ( $8/6$ ) factor 1.33 higher. B-C is therefore also a factor of 1.33 higher ( $2.7 \times 1.33$ ) = 3.59 cm. Side A-C can then be calculated with  $A^2 + B^2 = C^2$ .

We're going to **the third triangle**. Angle A =  $27^\circ$  and side A-C = 7 cm. How big are sides A-B and B-C? This is something different. If side A-B was 6 cm, then side B-C was 2.7 cm. In that case, side A-C would be calculated as follows:  $C^2 - A^2 = B^2$ ,  $(6^2 - 2.7^2 = 28.7^2)$   $\sqrt{28.7} = 5.358$  cm. However, A-C is 7 cm which is  $(7/5.358)$  factor 1.3 higher. A-B is then  $6 \times 1.3 = 7.8$  cm and B-C =  $2.7 \times 1.3 = 3.51$  cm

Then we go to **the fourth triangle**. What are the angles if side A-B = 5 cm and side B-C = 2 cm. Then calculate the factor of A-B. This is  $6/5 = 1.2$  less than 6. B-C is then 1.2 greater than 2 cm to get equal to 6 cm. B-C is then  $1.2 \times 2$  is 2.4 cm = 24 mm = equal to  $24^\circ$ . Angle A is therefore  $24^\circ$ . Angle C is  $90^\circ$ , so angle B is  $66^\circ$ .

So much for the easiest calculations. It gets a bit more difficult when we cross the  $30^\circ$  limit of the smallest angle.

Below are some examples of triangles.

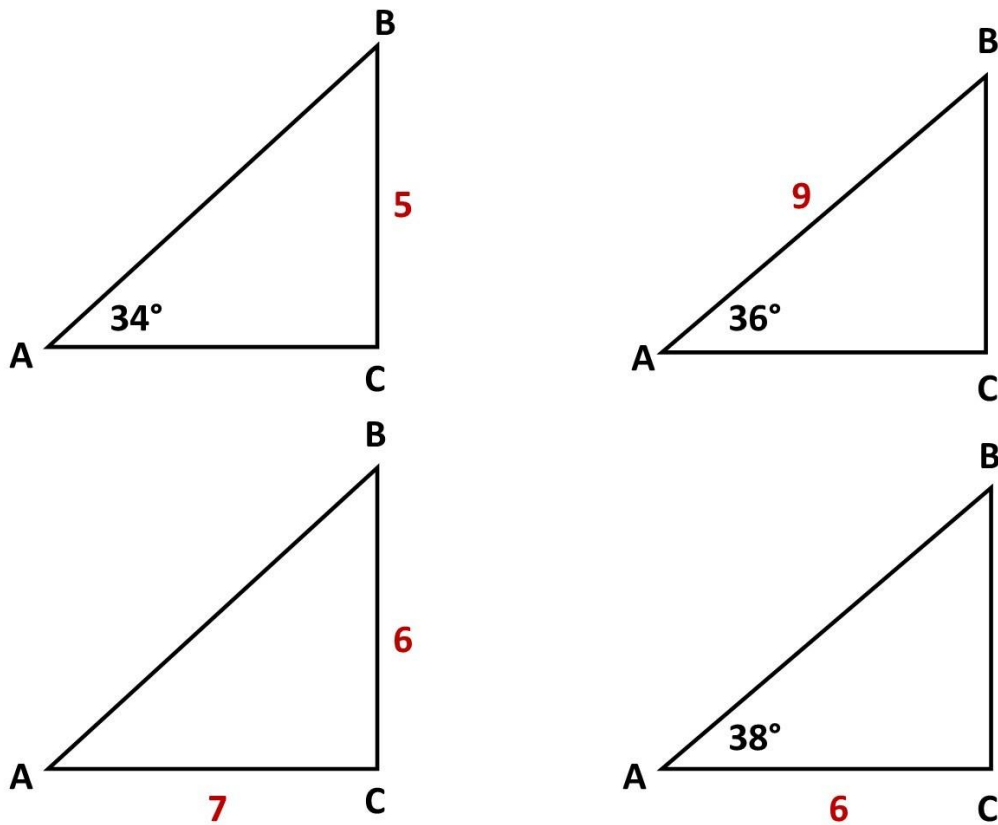

*Figure 9*

We will calculate the four triangles in figure 9, with figure 10 being the yardstick of the calculation.

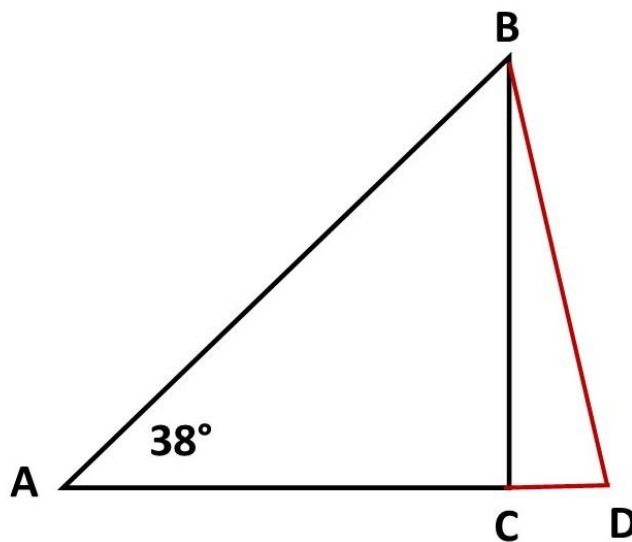

*Figure 10*

What you know is that if A-B and A-D are 6 cm, that B-D is equal in mm than the opposite angle in degrees.

**I'm going to calculate the first triangle in figure 9.**

Angle A = 34°. Side B-C = 5 cm. How big are sides A-C and A-B?

If we make the long sides equal, then A-B equals A-C + C-D. I am now going to calculate the side B-D and C-D.

We know that angle A is 34°. The other angles are then equal to (146/2) 73°. Knowing this, you can determine the angles of the smaller triangle B-C-D. These are 90° - 73° - 17°.

I am now going to determine side C-D. Determine the divide/multiplication factor by reducing the side B-D to 6 cm.

Suppose side B-D was 6 cm, then side C-D was 1.7 cm (opposite of angle B 17°). In that case, side B-C ( $C^2 - A^2 = B^2 = 6^2 - 1.7^2 = \sqrt{33.11^2}$ ) = 5.75 cm. However, side B-C is 5 cm. Now apply the divide/multiplication factor again.  $5.75/5 = 1.15$ . That means side C-D =  $1.7/1.5 = 1.13$  cm.

Side B-D is then ( $A^2 + B^2 = C^2 = 1.13^2 + 5^2 = \sqrt{26.27}$ ) = 5.12 cm.

If you now know that the following statement belongs to the angle of 34°.

*If the longest sides are equal to 6 cm, then the smallest side is the opposite angle in mm.*

What you see now is that the smallest side (B-D) in the example is 5.12 cm. This corresponds to an opposite angle of 51.2°. However, the angle is 34°. This means that side (B-D) is a factor of 1.5 greater.

The sides A-B and A-D are then  $6 \times 1.5 = 9$  cm. Side A-B is therefore 9 cm. If you now calculate side A-C, then that is  $C^2 + A^2 = B^2 = 9^2 - 5^2 = \sqrt{56} = 7.48$  cm.

**I'm going to calculate the second triangle in figure 9.**

Angle A =  $36^\circ$ . Side A-B is 9 cm. How big are sides A-C and B-C?

To get the right proportion, you have to make the two long sides equal. Side A-B equals side A-C + C-D.

If you now want to calculate side B-D, you need to convert 9 cm to 6 cm.

$9/6 = 1.5$ . Side B-D is then  $36 \times 1.5 = 5.4$  cm.

So, you also see that if the smallest top angle is 36 degrees, the other two are 72 degrees, angle D. If you now determine the degrees in the smallest triangle B-C-D, you see a triangle of 90, 72 and 18 degrees.

We are now going to determine side C-D.

We need to reduce B-D to 6 cm again.

$6/5.4 = 1.11$  cm. Angle B =  $18/1.11 = 16.21$  mm = 1.62 cm. Side C-D is therefore 1.62 cm.

Side B-C can now be calculated.  $C^2 - A^2 = B^2$ .  $5.4^2 - 1.62^2 = 29.16 - 2.62 = \sqrt{26.54} = 5.15$  cm.

Side A-C is  $C^2 - A^2 = B^2$ .  $9^2 - 5.15^2 = 81 - 26.52 = \sqrt{54.48} = 7.38$  cm.

**I'm going to calculate the third triangle in figure 9.**

Angle A =  $38^\circ$ . Side A-C = 6 cm. How big are sides A-B and B-C?

*With this triangle you have to do something different and that only if you have given side A-C.*

We are now going to equalize the longest sides. See figure 11.

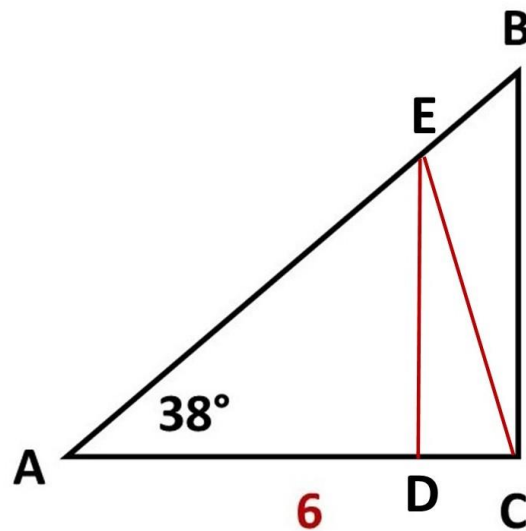

*Figure 11*

You do this by calculating the side E-C. Because side A-C is 6 cm, you do not have to reduce this side to 6 cm. In all other cases, yes. The side A-E is therefore 6 cm. Side E-C is equal to the angle of  $38^\circ$  in mm = 3.8 cm.

I'm going to calculate side E-D now. For this you need to know angle E. If you know that angle A is  $38^\circ$  then angles E and C ( $142/2$ ) are  $71^\circ$ . The angles of smallest triangle C-D-E are  $90^\circ - 71^\circ - 19^\circ$ .

If E-C is 6 cm, then D-C is 1.7 cm. However, E-C is 3.8 cm. In order to determine D-C, we need to reduce E-C to 6 cm. The divide/multiplication factor is then  $6/3.8 = 1.57$ . D-C is then  $19 (\text{angle A})/1.57 = 12.1 \text{ mm}$  is 1.21 cm.

Now you need to determine side E-D. This is  $C^2 - A^2 = B^2$ ,  $3.8^2 - 1.21^2 = 14.44 - 1.46 = \sqrt{12.98} = 3.6 \text{ cm}$ .

You now know that side D-C is 1.7 cm. Side A-D is then  $6 - 1.7 = 4.3 \text{ cm}$ .

Side A-C is larger than side A-D in proportion to a factor of  $6/4.3 = 1.39$ .

Side B-C is then 1.39 larger in relation to side E-D.

Side E-D = 3.6 cm. Side B-C is then  $3.6 \times 1.39 = 5.00$  cm.

Side A-C is given = 6 cm.

Side A-B is  $A^2 + B^2 = C^2$ .  $5^2 + 6^2 = \sqrt{61} = 7.81$  cm

**I'm going to calculate the fourth triangle in figure 9.**

How do you determine the angles of a right triangle if given two sides, A-C and B-C.

Side A-C = 7 cm and side B-C = 6 cm.

First you have to calculate the third side with  $A^2 + B^2 = C^2$ .

Side A-B is then 9.21 cm.

Now make the longest sides equal. A-B equals A-D. In that case, side C-D is 2.21 cm. Side B-D (figure 10) is now easy to calculate.  $A^2 + B^2 = C^2$ ,  $2.21^2 + 6^2 = \sqrt{40.88} = 6.39$  cm.

You know that the opposite side of angle A is equal in mm as its degrees, with two equal long sides of 6 cm.

Then I will determine the divide/multiplication factor. That's  $9.21/6 = 1.53$ . I am now going to reduce side B-D by a factor of 1.53. That brings us to  $6.39/1.53 = 4.17$  cm. This is rounded off 41 mm. And this is again equal to the degrees of angle A = 41°.

The other angles are then easy to determine,  $90^\circ - 41^\circ - 49^\circ$ .

What you notice in the calculations is that a lot of work is done with tenths and hundredths after the decimal point. This can sometimes lead to minuscule (in my opinion negligible) deviations.

If we now determine this fourth triangle according to the sine table, then the sine, dividing the opposite side (6 cm) by the hypotenuse (9.2 cm) = 0.652. And sine 0.652 is near 41°.

### How do you calculate the sides of any triangle?

An important factor is the determination of the missing side of an arbitrary triangle (not a right triangle), if two sides and an angle (and two angles) are known. So, how do you determine (and calculate) the third missing side of any triangle that is not a right triangle?

Let's take the right triangle as an example. The theorem  $A^2 + B^2 = C^2$  determines the hypotenuse, and the angle of 90° is always given. This means that in this calculation, 2 sides and an angle must be known.

Knowing this, I'm going to compare this to an arbitrary (not right-angled) triangle. How will you perform this calculation? See the example in figure 12 and 13,

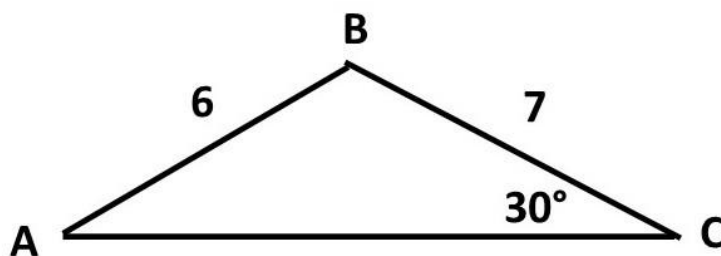

Figure 12

Determine the size of side A-C in figure 12.

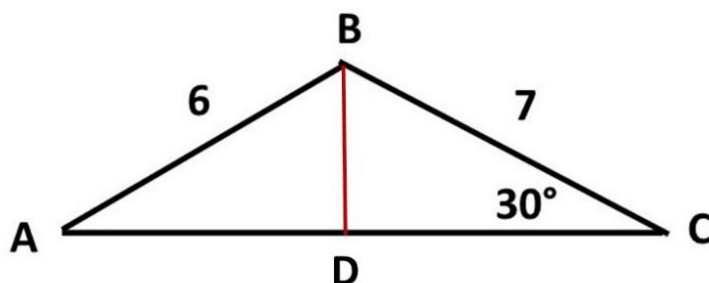

Figure 13

### How do you calculate this?



You start with an imaginary line B-D, figure 13. Angle D is then 90°. Angle B of the right triangle is then 60°. We are now going to calculate sides B-D and D-C. Since angle C is 30°, side C can be easily calculated. Side B-C is 7 cm. If it was 6 cm, then B-D would be 30 mm - 3 cm. We calculate the factor again.  $7/6$  is 1.16. So, B-D is  $1.16 \times 30 = 34.8 \text{ mm} = 3.48 \text{ cm}$ . Sides D-C are then  $C^2 - A^2 = B^2$ ,  $7^2 - 3.48^2 = \sqrt{36.89} = 6.07 \text{ cm}$ .

What you now know is that the left triangle is also a right triangle. Side A-B = 6 cm and side B-D we calculated = 3.38 cm. Then it is easy to calculate side A-D. That is,  $C^2 - A^2 = B^2$ ,  $6^2 - 3.48^2 = \sqrt{23.89} = 4.88 \text{ cm}$ .

Side A-C (figure 12) is then  $A-D + D-C = 4.88 + 6.07 = 10.95 \text{ cm}$ .

You see that if there is any triangle (not a right triangle) whose angle A or angle B and side A-B and B-C are known, then you can calculate side A-C.

For all other arbitrary triangles (not a right triangle), two angles must be known to determine the missing side. For example, if side A-C and A-B are known. Then calculate side B-C.

If you have studied the calculation of figure 12 and figure 13, you can test your own creativity in this.

***So, it indicates that with the knowledge of the equilateral triangle you can calculate all angles and sides.***

***I show that without sine, cosine, and tangent you can calculate the sides and angles of a triangle.***

So, you see how important the 6:6:6 ratio is. And how wonderful the equilateral triangle is.

If we connect 6 of these equilateral triangles, you get figure 14.

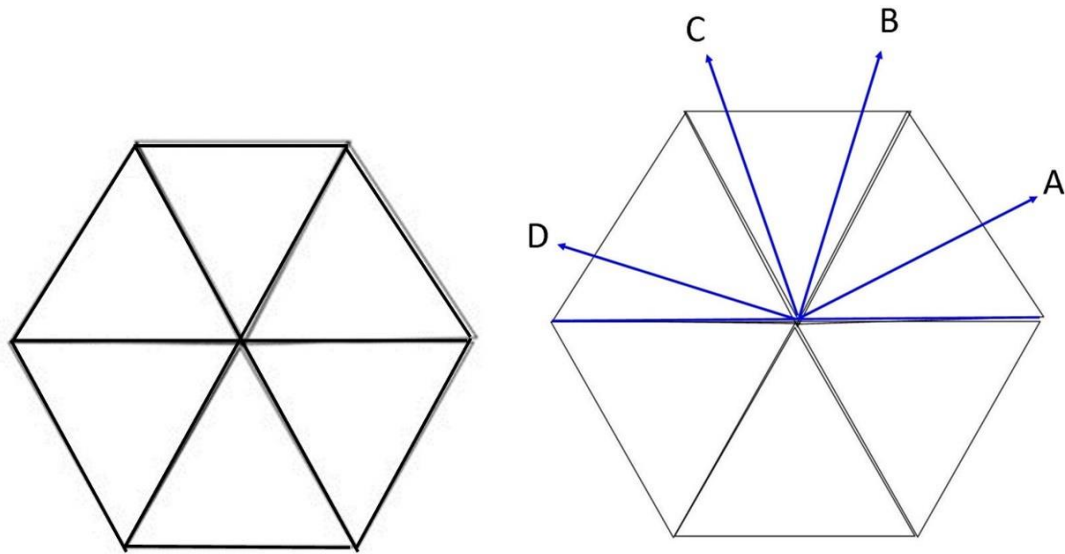

**Figure 14**

Working up one direction (in this case from right to left) you can measure any angle you want.

If you want an angle of 24 degrees (A), you measure 24 mm on the side. If you want to measure an angle of 70 degrees (B), you measure 10 mm in the second connected triangle. At C ( $112^\circ$ ) that is 52 degrees in the second connected triangle ( $60 + 52 = 112$ ). At an angle (D) of 160 degrees, that is 40 degrees off in the connected third triangle.

So, you don't need a protractor to determine the angles, although that is of course easy. Three connected equilateral triangles in the ratio 6:6:6 replace the protractor.

Now if you think it's easier to take the protractor instead of putting three equilateral triangles together, you're right.

There is another difference, and I will come back to that in a moment.

The protractor is a mold, made of plastic, wood or metal. Almost every math package in modern times contains a protractor (geo-triangle), a right-angled and isosceles triangle, a ruler, and a compass.

All tools to make things easier for us.

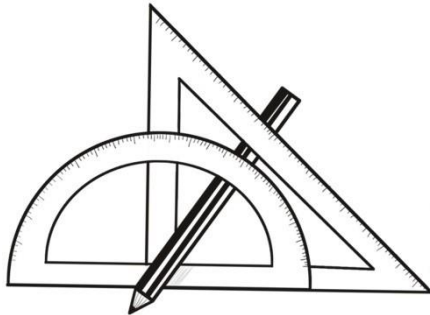

In earlier times also had this kind of molds (tools). For example, they had a Hexagram (a six-pointed star).

What could you do with this? See figure 15.

So, without having to draw the 6 triangles, you could use the Hexagram whose points are 60 mm (60°) apart in the correct proportion.

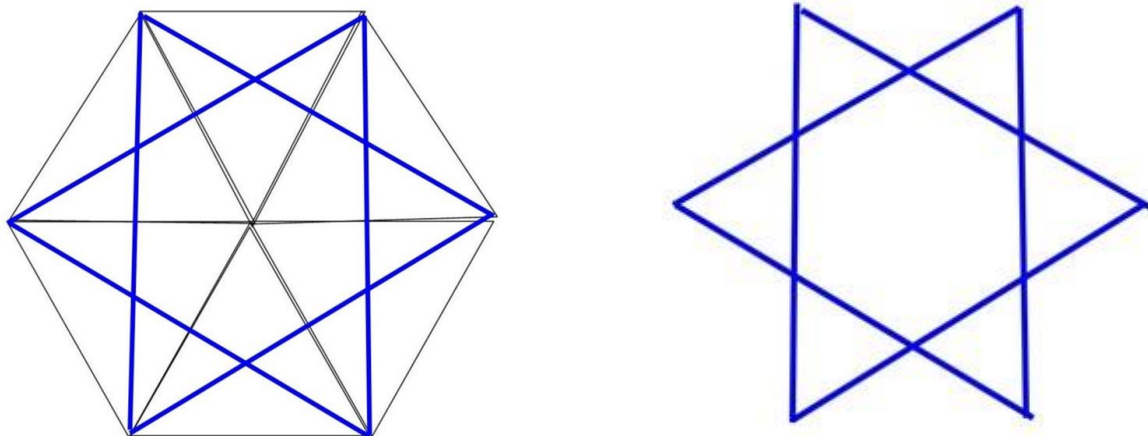
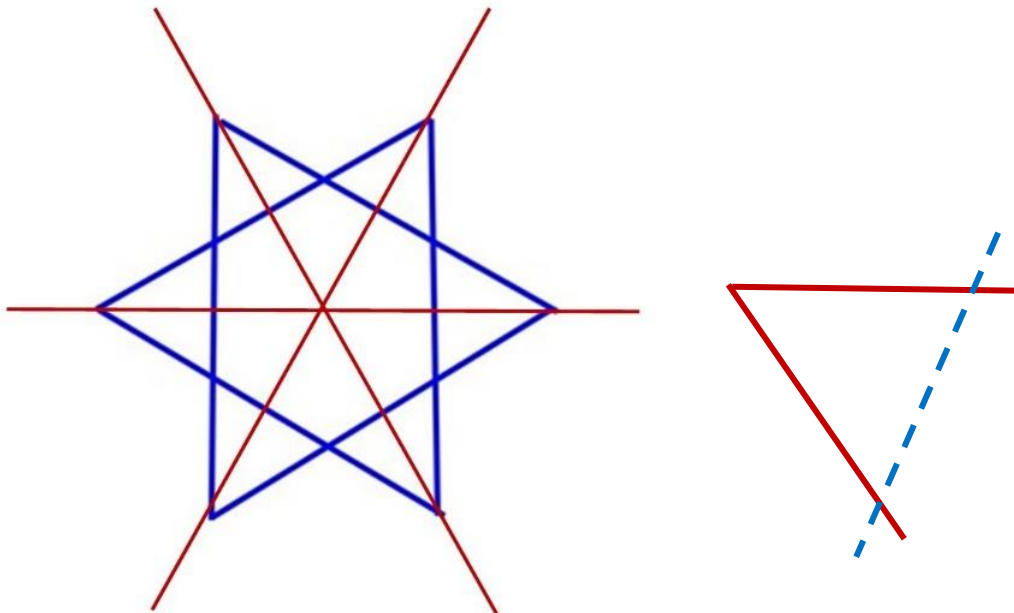

**Figure 15**

How did that work?

They picked up a Hexagram that was possible in arbitrary sizes. A Hexagram that what compared to the correct size, did not have to be size bound. The Hexagram was placed on, for example, paper, see figure 16.

You put a dot on each point of the Hexagram. Then you connect the lines. You can make the lines as big (long) as you want. You have the center. It is now important to take the standard 6:6:6 ratio as a benchmark. Suppose your move is 18 cm out on the lines. Then the measure of angle determination (dashed line) is  $18/6$ . In that case you should measure 3 mm per degree.



**Figure 16**

Just as the protractor is used as a standard template in our math package in modern times, in the past in pyramid construction an equilateral triangle of 60 cm (1 cm for each degree) was used as a standard template. You have to ask yourself, which is easier, plotting degrees on a curved line or on a straight line?

There is one more thing you should know. The protractor as a standard template was only created after the degrees of the circle were known. Because suppose you have a protractor without lines and numbers (blank). Can you measure 360 equal parts on a circle with this?

Suppose you have a blank circle. How do you divide this blank circle into 360 equal parts? And then make it a standard circle. How do you do that? You won't succeed with a blank protractor and a ruler.

Well with a ruler and an equilateral triangle of  $60^\circ$  in the ratio 6:6:6. The predecessor of the Hexagram.

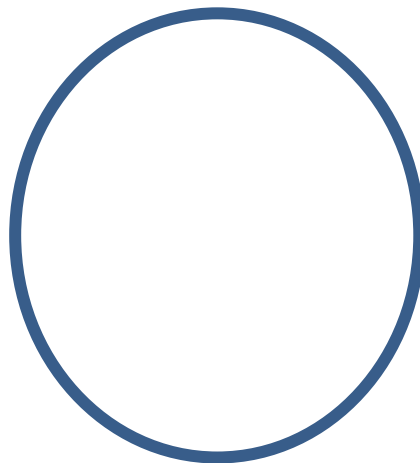

**The cord with 9 knots proves the old craft.**

In fact, in the old days a 9-knot cord was enough to make every corner.



**Nine knots in an equidistant cord**

We know that with the cord of nine knots we can make a right angle.

Make a rope with nine equally spaced knots. Fasten the first knot in one spot. Then take the sixth knot and fasten (mark) it in a tight line. Then take the eighth knot and exchange it with the (marking) attachment point of the sixth knot and then pull the line taut in the ratio 4:5. You then have a right angle.

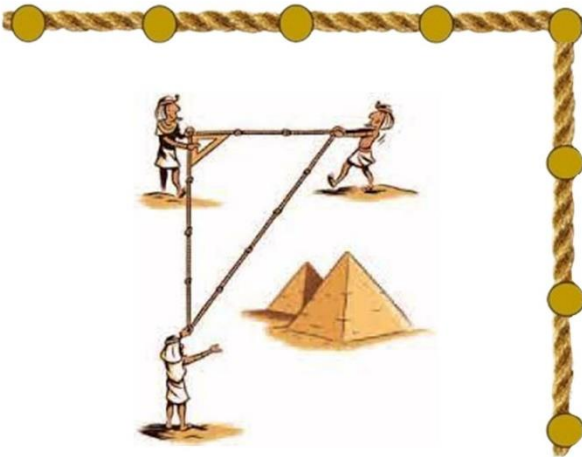

What we don't know is that with a cord of nine knots we can also make a hexagon, which, when properly laid, can determine the angles of the circle as indicated in advance. If you make nine equally spaced knots in a rope you can make figure 17.

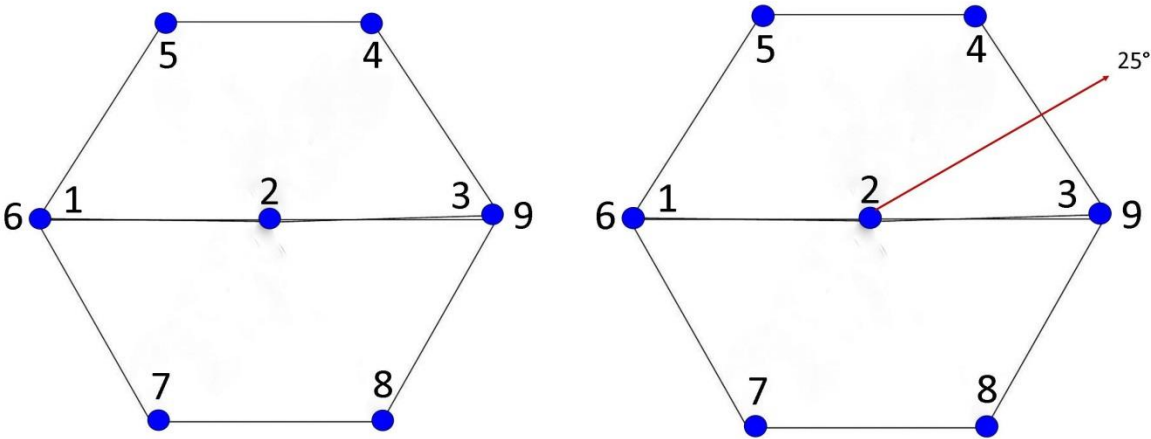
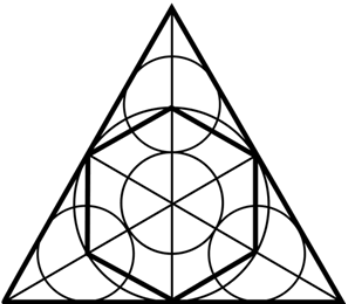

Figure 17

If you want to enlarge the angles 10 x to centimeters then you need 360 cm for the circumference (3 - 9) and for the diameter (1 - 2 - 3) 120 cm, making a length of 480 cm.

We now return to the (golden) equilateral triangle. I have explained the importance of the 6:6:6 ratio. The entire trigonometry changes as a result. I have shown you that an equilateral triangle of 6 cm corresponds to 60 degrees on the circle.



Six equilateral triangles that connect to each other complete the 360° circle.

**Now, however, I'm only going to draw one equilateral triangle.**

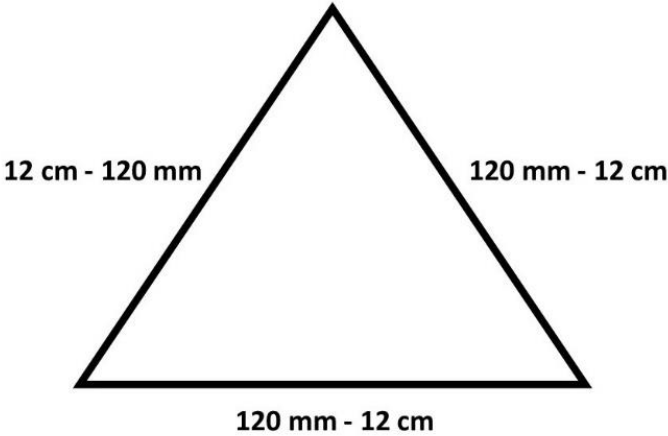

**Figure 18**

An equilateral triangle measuring 12 cm - 120 mm - 120°, figure 18.

What can we do with this?

Draw a circle around the 12 cm equilateral triangle.

Determine the center of the triangle, see figure 19.

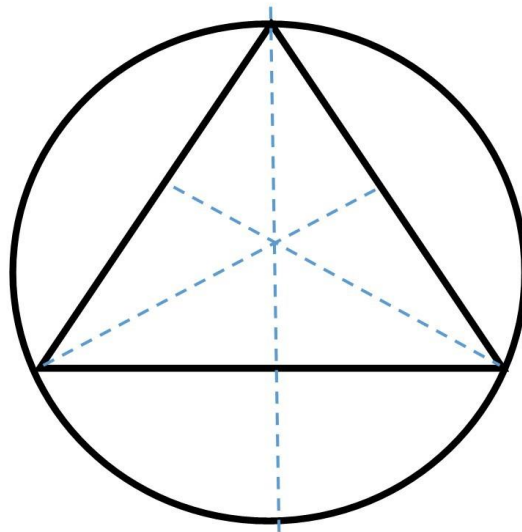
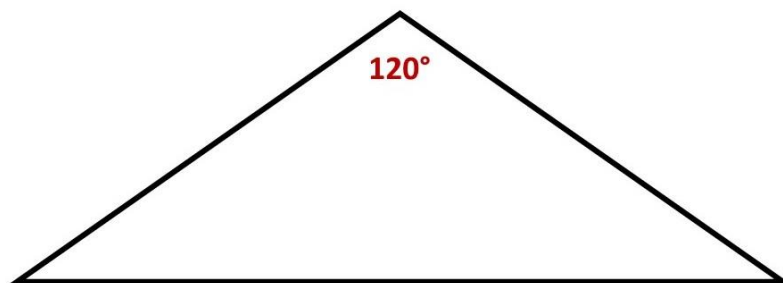

Figure 19

You can now observe that seen from the center, the triangle shows 3 angles of  $120^\circ$  compared to the circle.



How can you determine an angle from this  $120^\circ$  triangle that is equal to the circle angle, without having to use a protractor?

How do you shape that geometrically?

Suppose you want an angle of  $20^\circ$ . You then measure 20 mm on the 120 mm line B-C (point D), see figure 20.



Now draw a straight line from angle A through point D to the circle.

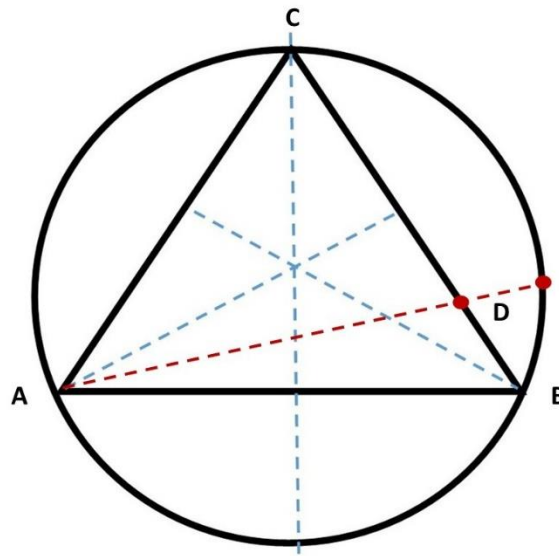

Figure 20

Then draw a straight line from the center (M) to the circle point E, see figure 21.

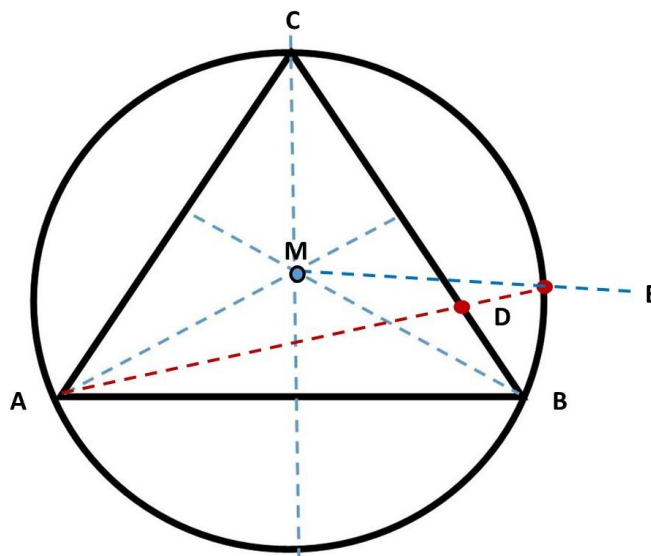

Figure 21

**Angle B - M - E = 20°**

## The Great Pyramid.

What can we bring back in this modern age in relation to the Great Pyramid? To do that you need to understand the core of the Pyramid Building.

It is now stated in 2022 that the Great Pyramid of Giza in Egypt was originally 146.59 m high and has a square base of 230 m on each side. The height of the Pyramid at the moment 2022 is 138.75 m.



If you look closely, the Great Pyramid is made up of 4 sides (4 equilateral triangles with angles of  $60^\circ$ ) and a square base. This is how the architectural building plan should be.

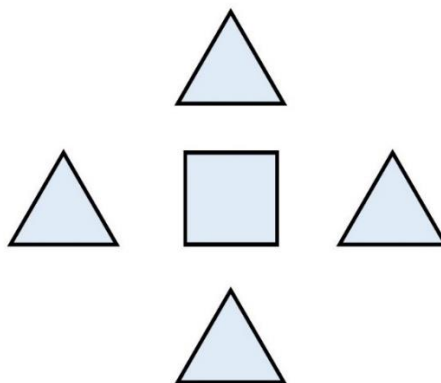

However, if you put the measurements of the Pyramid next to the building plan, this is not correct.

Suppose the height B of the Pyramid is 146.59 m. How large is the hypotenuse C. Figure 22.

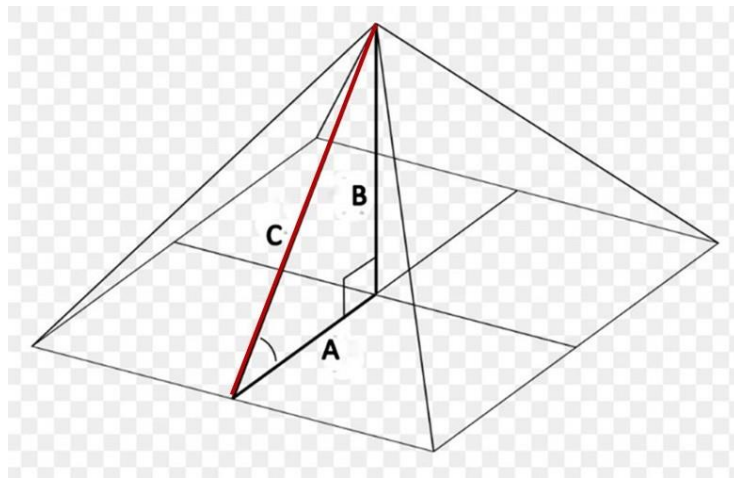

Figure 22

Side A =  $230/2 = 115$  m. Side C is then  $A^2 + B^2 = C^2$ . This makes  $115^2 + 146.59^2 = \sqrt{34,819.3} = 186.6$  m.

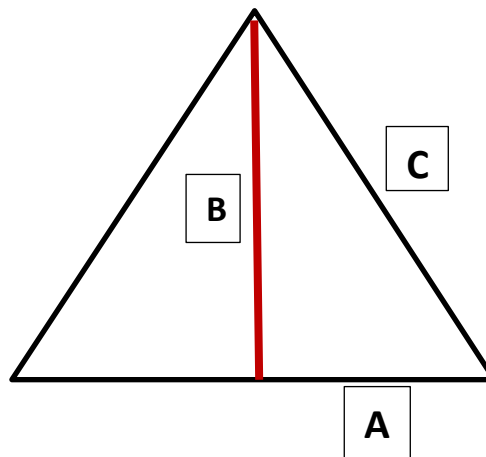

Figure 23

Side C is the hypotenuse of the inner triangle (figure 22) in the Pyramid. Seen from the outside, it is the straight side B of the right-angled triangle (figure 23), formed from the Pyramid plane (equilateral triangle). How big is the hypotenuse C on the outside, figure 23?

Hypotenuse side C is then  $(A)115^2 + (B)186.6^2 = \sqrt{48044} = 219$  m.

What does this mean? If we now assume that these measurements are correct with the intended building plan of the then Egyptian architects, then I completely doubt this. Because then this would mean that the Egyptian Great Pyramid is built under the 4 triangle surfaces as shown in figure 24 and a square base of 230 meters.

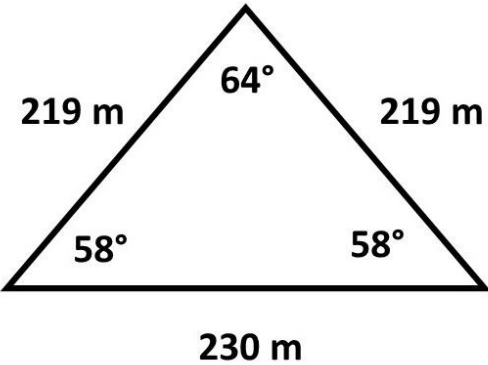

Figure 24

I don't know of any architect in the world who would design such a structure. It's chaos in the triangle. What does make sense is the perfection as the building plan should be. Four equilateral triangles as shown in figure 25 and a square base of 230 meters.

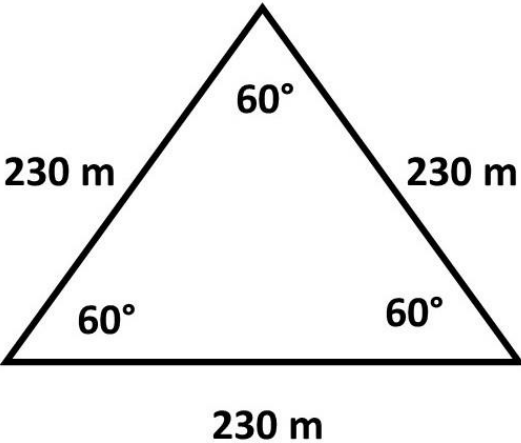

Figure 25

Such is the original building plan of the Egyptian Great Pyramid in the eyes of an architect.

It is understandable, logical and predictable that structures crumble and sag after 4,000 years. That goes for every house that people build in this world.

If you now use the measurements in your calculations of a dilapidated (or not one hundred percent cleanly built) building, the calculations will deviate from the original construction plan.

In my opinion, scientists from the past did not pay attention to this building plan and made calculations based on what they saw.

Considering the fact that the top of the Pyramid had been taken away and crumbled, its height was calculated on what was thought to be good.

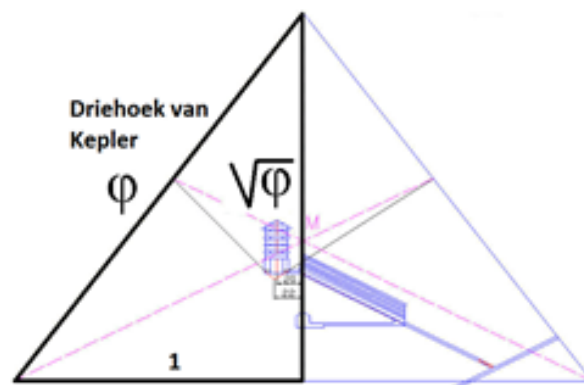

**Figure 26**

Kepler calculated the height of the Pyramid based on what was seen at the time, figure 24 and figure 26. He applied the ratio 1:  $\phi$ :  $\sqrt{\phi}$ .

(A)1 = 115 m. (C)  $\phi$  is then  $115 \times 1.618 = 186.07$  m and (B)  $\sqrt{\phi}$  is  $115 \times \sqrt{\phi} = 1.272 = 146.28$  m.

My calculations are different. They are based on the architectural building plan, based on logic and architectural insight, figures 25 and 27.

I apply the ratio  $v1 : v2 : v3$ . (A)  $v1 = 115$  m. (B) (height)  $v2 = 162.63$  m, (C)  $v3 = 199.18$  m. All this based on an equilateral triangle on the outside of the Pyramid.

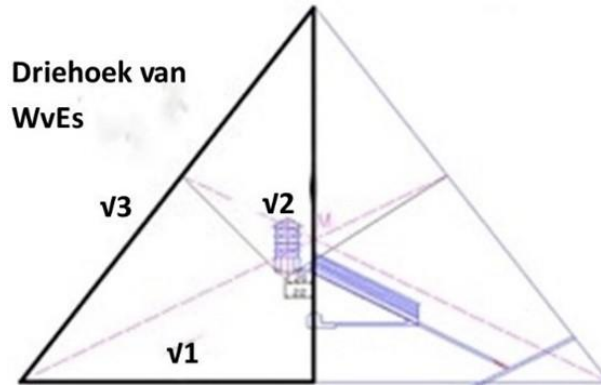

**Figure 27**

Kepler's triangle ( $1: \phi: \sqrt{\phi}$ ) and mine ( $v1 : v2 : v3$ ) are based on the inside (angle  $36^\circ, 54^\circ, 90^\circ$  figure 28) of the Pyramid.

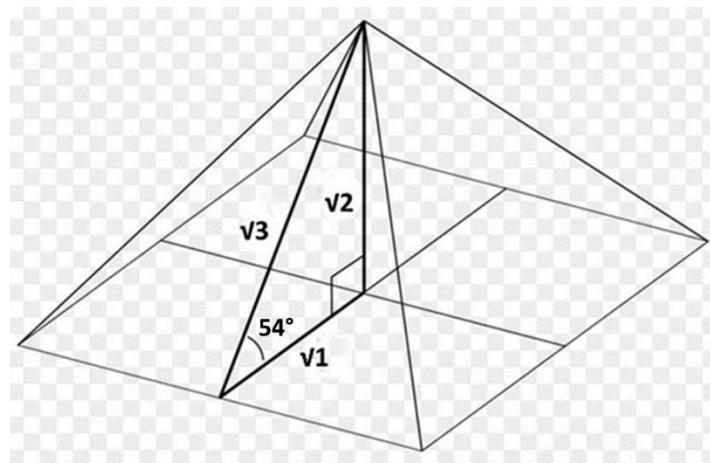

**Figure 28**

We can now put my relationship to a test. And see what it gets you.

For this we are going to reduce the Pyramid to a workable ratio, where the ratio (666) 6:6:6 is the starting point.

If we simplify the Pyramid to 6 cm, you get figure 29. A base with 4 sides of 6 cm (60 mm) and 4 equilateral triangles with 3 sides of 6 cm (60 mm) and 3 angles of 60°.

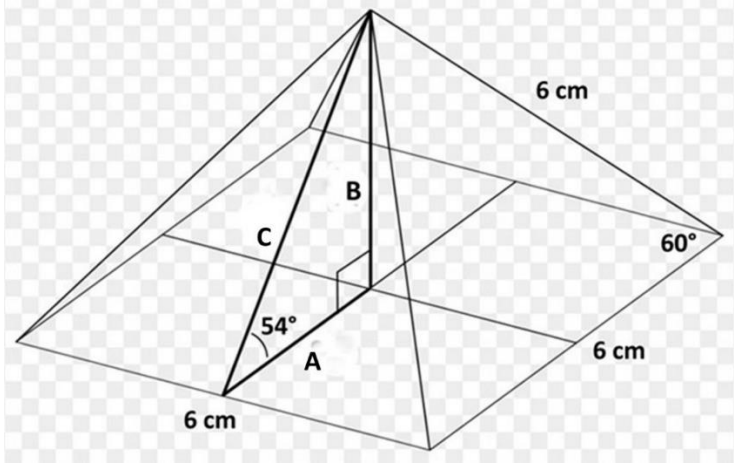

Figure 29

If we now divide it into pieces, you will see the following: figure 30.

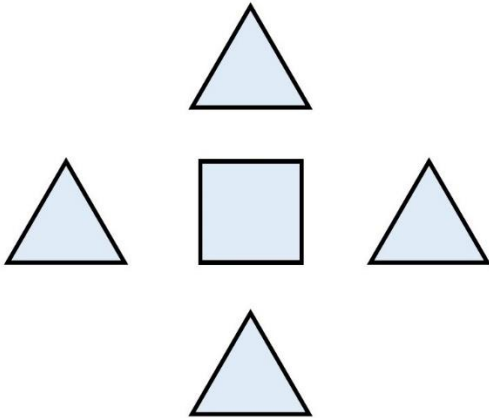

Figure 30

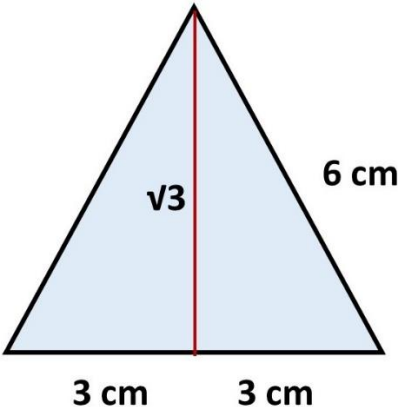
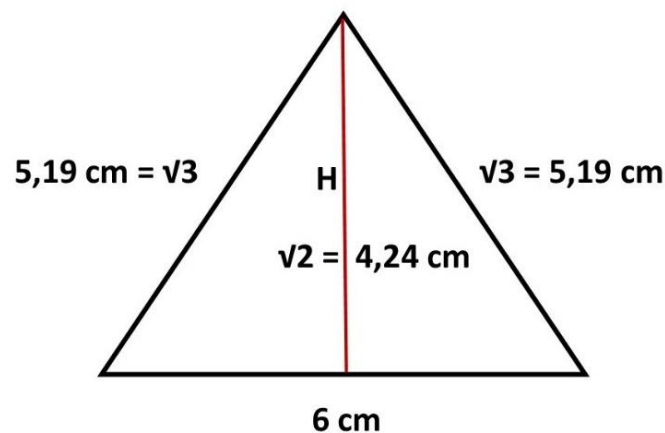

Figure 31

Figure 31 shows the equilateral triangle. If we divide this triangle in two, you get a right-angled triangle with the dimensions 6 cm x 3 cm x ( $\sqrt{3} \times 3$  cm) 5.19 cm.

Now if we put the points of the four triangles together, you get the Pyramid.

What are the dimensions of the converging straight lines? These are the lines  $\sqrt{3}$ , in this case 5.19 cm, see figure 32.



**Figure 32**

The height can then be quickly measured and calculated; this is 4.24 cm =  $3\sqrt{2}$ .

As I mentioned, the 6:6:6 ratio is essential. It's a perfect ratio. The entire trigonometry is geared to this.

What else do you see in the triangle  $\sqrt{1} : \sqrt{2} : \sqrt{3}$ ?

You can read the perfect number pi ( $\pi$ ) from it.

$\text{Pi} (\pi) = \sqrt{2} + \sqrt{3}$  divided by  $\sqrt{1}$ .

$\text{Pi} (\pi) = 4.24 + 5.19 = 9.43 / 3 = 3.14333333333333333333 \dots\dots$

If you deviate from the ratio 6:6:6, you will not get the perfect number pi ( $\pi$ ) but the number pi, slightly deviating in the thousandth decimal place.

An example is the Great Pyramid on the Giza plateau in Egypt. Taking into account the dimensions of the architectural plan of the equilateral triangle in figure 25, you can easily determine pi ( $\pi$ ), without consciously using the triangle  $\sqrt{1} : \sqrt{2} : \sqrt{3}$ .



All you must do is measure and add up the two straight sides ( $\sqrt{3}$  sides) on the outside of the Pyramid. Then add the height twice. And divide all that by the base ground side.

$$\sqrt{3} (199.18 \times 2) + \sqrt{2} (162.63 \times 2) = 398.36 + 325.26 = 723.62 / 230 \sqrt{1} = 3.1461 \dots$$

The special feature of the triangle  $\sqrt{1} : \sqrt{2} : \sqrt{3}$  is that it also shows the circumference and diameter of a circle.

$\sqrt{1}$  in this case is the diameter and  $\sqrt{2} + \sqrt{3}$  is the circumference.

Suppose you have a diameter of 12 cm. Then what is the circumference of the circle:  $12 \times 3.1433333$  is 37.7199 ... cm (rounded off 37.7 cm).

If you now project this into the triangle  $\sqrt{1} : \sqrt{2} : \sqrt{3}$  figure 33, then  $\sqrt{1} - 12$  cm,  $\sqrt{2} - 16.97...$  cm and  $\sqrt{3} - 20.78... = 37.75...$  (rounded off 37.7cm)

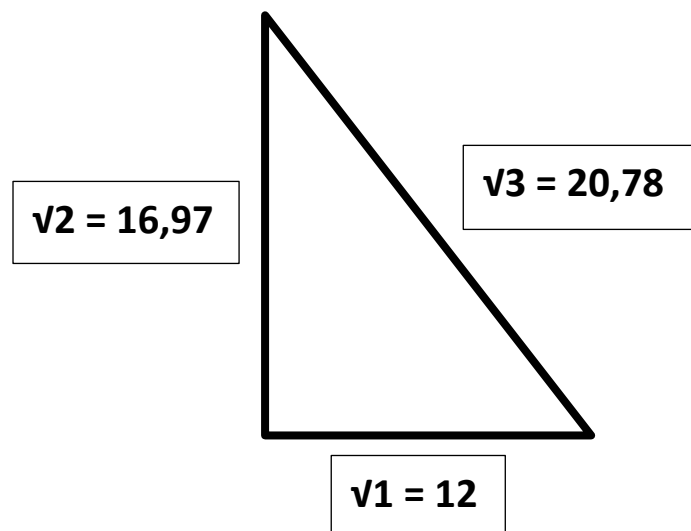

Figure 33

**Figure 33 shows that you can project the circle as a triangle.**

In this book I also show you how you can calculate the number pi ( $\pi$ ) in several ways based on perfect geometric substantiation.

All these calculations deviate slightly in the thousandths of decimal places and are therefore negligible.

***My advice is to stick to one pi ( $\pi$ ) number and that is the number pi ( $\pi$ ) tuned to the perfect (pyramid) ratio 6:6:6. ( $9.43/3 = 3.1433333...$ )***

***I am now going to show you on the basis of the triangle  $\sqrt{1} : \sqrt{2} : \sqrt{3}$  where the theorem  $A^2 + B^2 = C^2$  comes from its origin.***

The theorem is named after the Greek mathematician Pythagoras (540 BC), but the theorem was only new to the Greeks. It was used before in Babylonia and ancient Egypt. In particular, the ratio 3:4:5 between the two rectangular sides and the hypotenuse was used early on to measure right angles, as it is done by some to this day.

I show you in figure 34 that this ratio is not pure at the origin of the theorem  $A^2 + B^2 = C^2$ . I explain to you why.

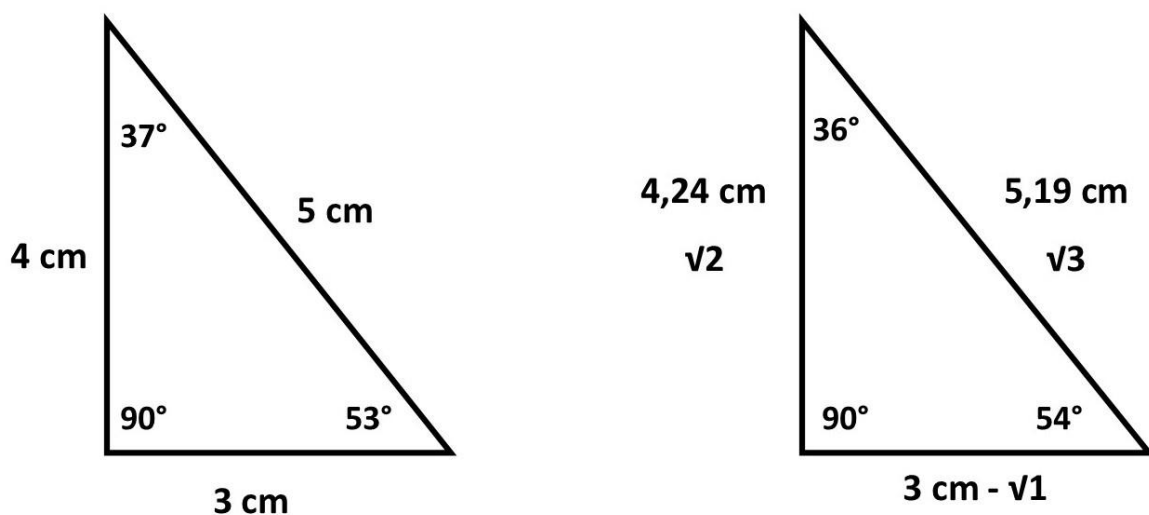

**Figure 34**

The 3:4:5 ratio has no connection whatsoever with the Pyramid. The ratio  $\sqrt{1} : \sqrt{2} : \sqrt{3}$  does.

We are now going to apply a trigonometric calculation test to these triangles, see figure 35.

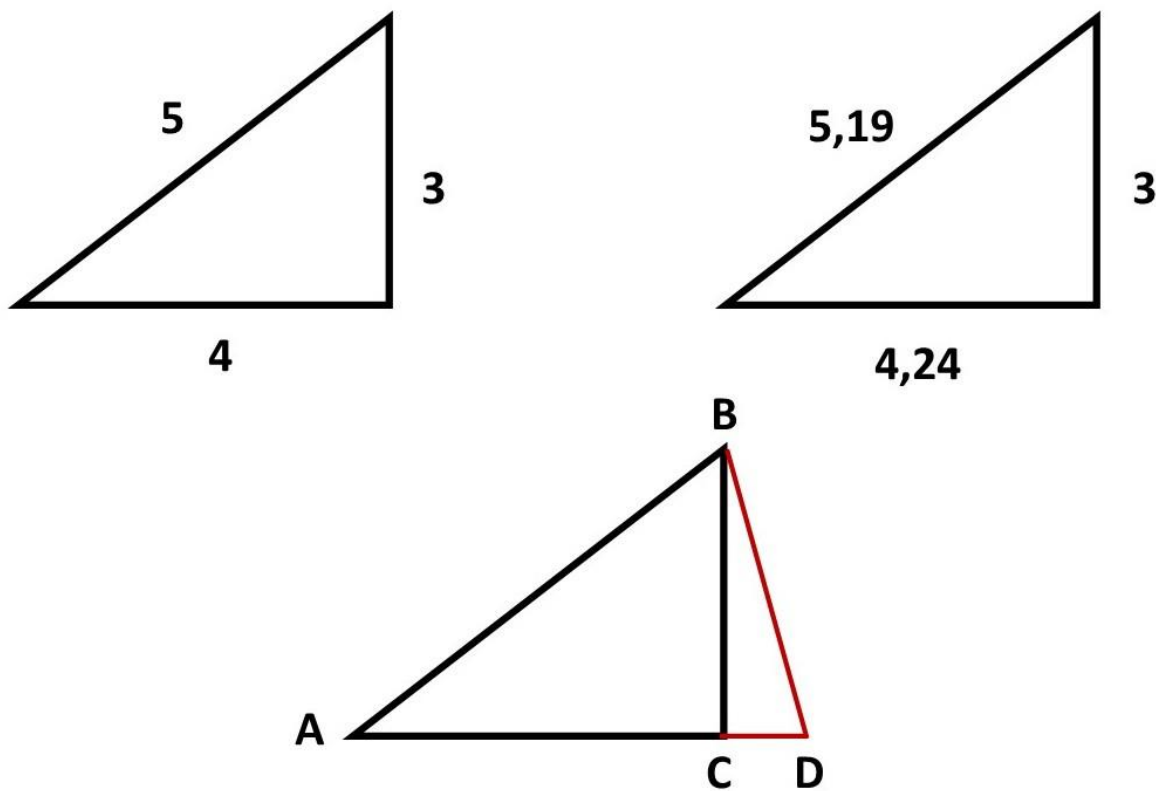

Figure 35

According to the sine table, the distribution factor can be read at the appropriate degrees of the angle. Sine is according to the table dividing the opposite straight side by the adjacent hypotenuse:  $3/5 = (\text{factor}) 0.6$ . On the sine table you can read that the angle that belongs to this is  $37^\circ$ . Some factors of the table with corresponding angles are:  $0.574 = 35^\circ$ ,  $0.588 = 36^\circ$ ,  $0.602 = 37^\circ$ ,  $0.616 = 38^\circ$ .

You may wonder if this is correct? Or that they are "approximate angles"?

The pyramid triangle will then have a better approximation if you round it to 1 decimal:  $3/5.1 = 0.588 = 36^\circ$ . However, this no longer corresponds with the number pi  $\pi$ . If I compare the right size, the sine factor is  $3/5.19 = 0.578$  and it lies between  $35^\circ$  and  $36^\circ$ .

We are now going to do it more perfectly with my trigonometric method. The 'hand' calculation, my method as I have already explained.

So, we know that in an isosceles triangle below  $60^\circ$ , the opposite side of the smallest angle is equal to the angle in mm, if the equal hypotenuses are 6 cm.

If we now look at figure 39, A-B is equal to A-D in the first case, so 5 cm. C-D is then 1 cm. B-D is then  $C-D^2 + B-C^2 = 1^2 + 3^2 = \sqrt{10} = 3.16$  cm. If we now want to determine the angle A of the triangle 3:4:5, then this side 5 is reduced to 6. This results in the division factor  $(6/5) 1.2$ . Then increase side B-D by the factor 1.2, this makes  $3.16 \times 1.2 = 37.9^\circ$ .

Angle A is therefore in the triangular ratio 3:4:5 =  $37.9^\circ$ .

If you are going to measure this yourself by drawing the triangle as accurately as possible, you will see that it is approximately  $38^\circ$ . This is  $1^\circ$  difference compared to the determination in the sine table.

Now you can say that  $1^\circ$  is negligible. You can, but that doesn't mean it can be done better.

I am now going to test the pyramid triangle  $\sqrt{1} : \sqrt{2} : \sqrt{3}$ . See figure 35. C-D is then  $5.19 - 4.24$  is 0.95 cm. B-D is then  $C-D^2 + B-C^2 = 0.95^2 + 3^2 = \sqrt{9.9025} = 3.146$ .

The distribution factor is then  $6/5.19 = 1.15$ . Multiplied by 3.146 makes  $36.1^\circ$ . Angle A =  $36^\circ$ .

So, you may wonder which is better? My trigonometric hand calculation or the sine, cosine, tangent, table determinations?

The triangle in the ratio 3:4:5 is still the basis of the theorem  $A^2 + B^2 = C^2$ . This for centuries. It is clear that this theorem works, but no one knows where this theorem has its origin.

The ratio 3:4:5 has its square ratio in 9:16:25.

The proof is provided in areas.

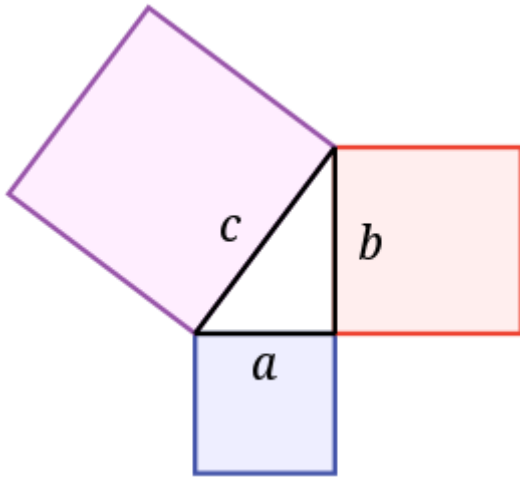

However, it does not indicate where this theorem originates from.

So it arises from the pyramid triangle  $\sqrt{1} : \sqrt{2} : \sqrt{3}$ .

What is the beginning of the fixed number count: 1,2,3,4,5 etc. What is the least squares ratio? So, this is 1:2:3.  $1+2=3$ .

If we link the statement to 9:16:25 then we are a long way from the beginning. So the triangle from 9:16:25 is  $\sqrt{9} : \sqrt{16} : \sqrt{25} = 3:4:5$ . If we link the theorem to the ratio 1:2:3, then we have the beginning, so the triangle from 1:2:3 is  $\sqrt{1} : \sqrt{2} : \sqrt{3}$ . And this ratio is within the pyramid.

The 3:4:5 ratio has no connection whatsoever with the pyramid.

***The pyramid triangle  $\sqrt{1} : \sqrt{2} : \sqrt{3}$  shows the following: the theorem  $A^2 + B^2 = C^2$ , the number Pi  $\pi$ , the diameter and circumference of a circle.***

What makes the triangle  $\sqrt{1} : \sqrt{2} : \sqrt{3}$  special are the angles  $36^\circ$ ,  $54^\circ$  and  $90^\circ$ . The angle of  $36^\circ$  is connected to the pentagram. And I'm going to discuss that now.

### The pentagram.



The pentagram is a five-pointed star that represents a pentagon. We are now going to put these next to each other, see figure 36.

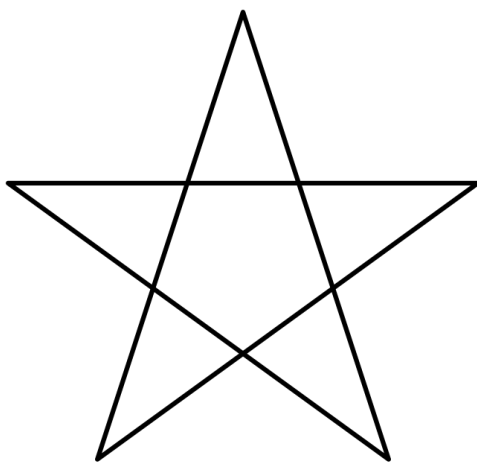

**Pentagram**

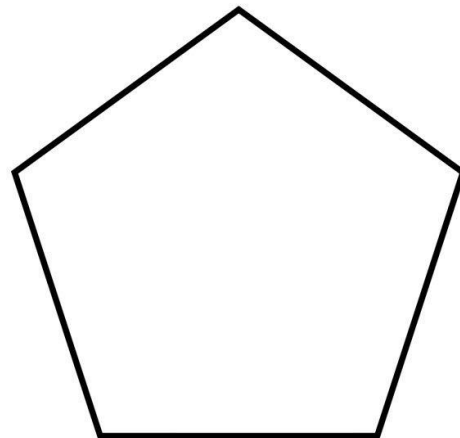

**Pentagon**

**Figure 36**

What we know of the pentagram is the representation in the circle, see figure 37. What we hardly see is the representation of the pentagram in the pentagon.

Everything is based on the pentagram in the pentagon.



*Pentagram in Circle*

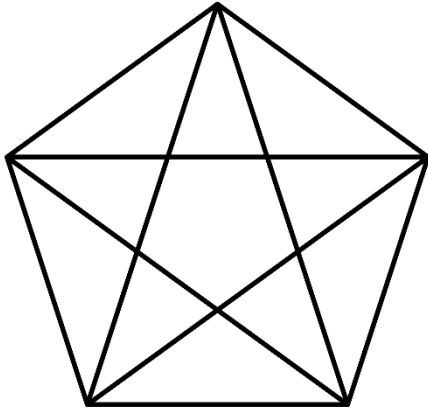

*Pentagram in pentagon*

**Figure 37**

**The pentagon.**

What do you see when you divide the pentagon into lines, as shown in figure 38?

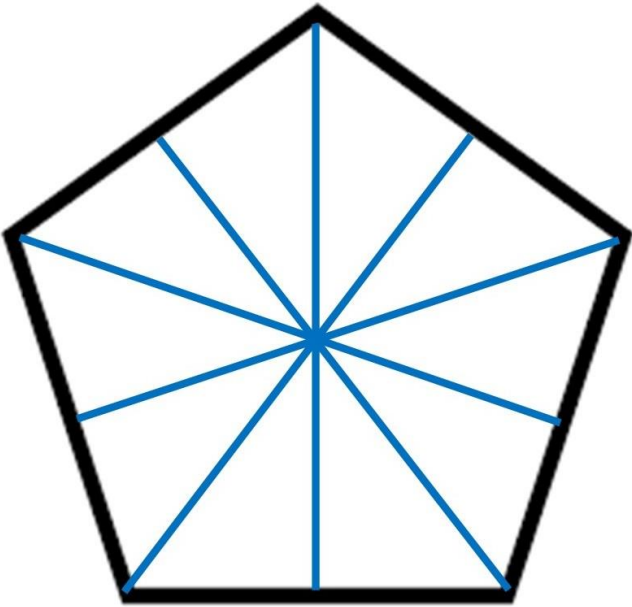

**Figure 38**

You see 10 triangles come forward. There will undoubtedly have been people who have done this spontaneously. Presumably, they did not know what they were seeing, because they were not familiar with the triangle ratio  $\sqrt{1} : \sqrt{2} : \sqrt{3}$  and its meaning.

In this case, you see 10 triangles in the ratio  $\sqrt{1} : \sqrt{2} : \sqrt{3}$ . So, you see 10 times the squared ratio  $A^2 + B^2 = C^2$ , you see 10 times the ratio  $\pi$ , and you see 10 times the ratio circumference - diameter, as I explained.

In the circle pentagram, you cannot perceive all this.

Everything I describe is based on the pentagon pentagram.

### **The pentagon pentagram.**

We are now going to draw the pentagram in the pentagon, as shown in figure 38.

Figure 39 shows what this would look like.

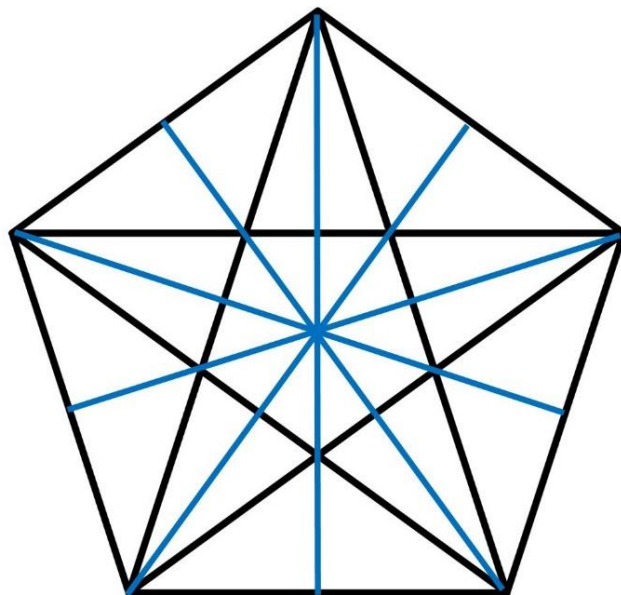

**Figure 39**

What do you see in the combination pentagon-pentagram?



You see 38 triangles in this combination (pentagon pentagram), in the ratio  $\sqrt{1} : \sqrt{2} : \sqrt{3}$ .

So, there is projected 38 times the squared ratio  $A^2 + B^2 = C^2$ , 38 times the ratio  $\pi$ , and 38 times the ratio circumference - diameter.

And no one ever knew this.

What you observe in the pyramid (Great Pyramid of Giza) are four angles of  $36^\circ - 54^\circ - 90^\circ$ . The ratio  $\sqrt{1} : \sqrt{2} : \sqrt{3}$ . There are 38 in the pentagram if you look closely.

If we now project the pentagon pentagram into the circle, you will see figure 40.

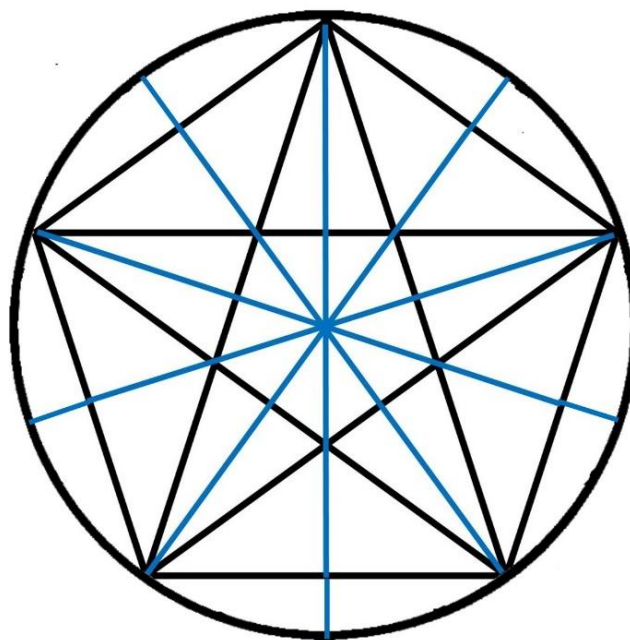

**Figure 40**

It is now important to show perfect geometry. This means that you must draw (project) all this in a pentagram ratio, of which the pentagram sides are 12 cm.

If you have done this correctly, you will see that the sides of the pentagon are 72 mm, which again correspond to the 72° triangle that you can observe in the pentagram. Five angles of 72° make 360°, and that completes the circle.

It's about this triangle.

The triangle in the ratio 72° : 54° : 54°.

If you draw the pentagram sides at 12 cm, you get a triangle like this: base side 7.2 cm, the height 5.09 cm, the two hypotenuse sides 6.23 cm.

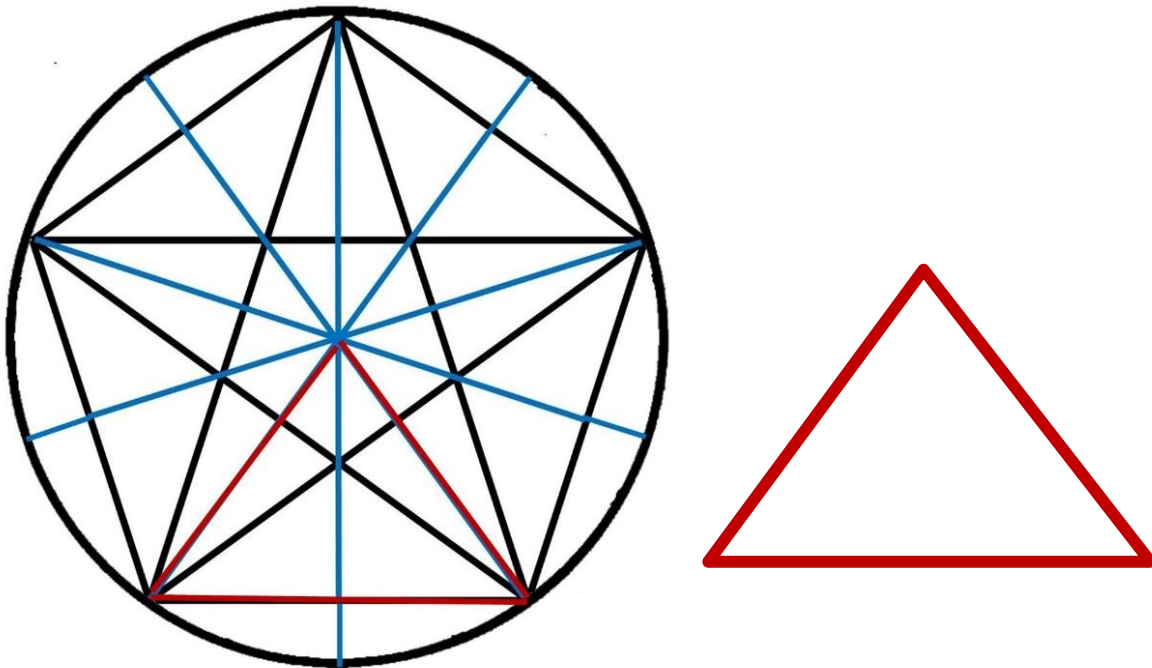

Figure 41

Figure 41 shows this triangle. You see two triangles in the ratio 36° - 54° - 90° next to each other.

## **The number Pi and the mathematical fraction 22/7.**

### **What does the number Pi say on the internet?**

*"Pi is a number that cannot change in mathematics: in short, a mathematical constant. The decimal notation of the number  $\pi$  forms the number value 3.14159 26535 89793 23846 26433 83279 50288... The number represents the ratio between the circumference and the diameter or diameter of a circle."*

This is how it can be found on the internet.

*Personally, I find the outcome of this number a conclusion that I doubt.*

### **The mathematical fraction 22/7.**

*"A commonly used approximation of the number Pi is the fraction 22/7 = 3.142 857 142 857 ... Of which three digits are good, but you also have to remember three digits for it."*

This also can be found on the internet.

So, the question is, how do we get at these determinations and are they determined according to the exact geometry?

We are going to investigate this.

### **How do we get to the mathematical fraction 22/7?**

It could just be that we don't know the answer to this. It can be found in the triangle  $72^\circ : 54^\circ : 54^\circ$ .

What you can now clearly observe is that many subjects were determined inaccurately in the past. This is reflected in the dimensions of this triangle and in the dimensions of the pyramid triangle.

Because of these impurities, a lot of knowledge has been left behind.

If we go back to the triangle in the ratio: 3:4:5 (fixed measures, without decimals) then it is easy to count, and one can easily calculate with it.  $A^2 + B^2 = C^2$ ,  $9 + 16 = 25$ . It is not known where the deeper core lies. The evidence is sought in the surfaces. Furthermore, not much can be done with this triangle in the ratio: 3:4:5. I have shown you the ratio originated from the pyramid. The triangle ratio: 3 : 4.24 : 5.19. It's these two decimal places that make the difference and reveal a lot that you didn't know.  $A^2 + B^2 = C^2$ ,  $(3 - 4.24 - 5.19)$ ,  $(9 + 18 = 27)$ .

**This also happened with the mathematical fraction 22/7.**

The decimals have been omitted. Figure 42 shows what then happens. What do you see then? You no longer see the triangle 36° - 54° - 90° in the sizes 3.6 cm, 5.09 cm, 6.23 cm ( $\sqrt{1} - \sqrt{2} - \sqrt{3}$ ).

What you do see, is a triangle in the ratio 35° - 55° - 90° in the sizes 3.5 cm, 5 cm, 6 cm.

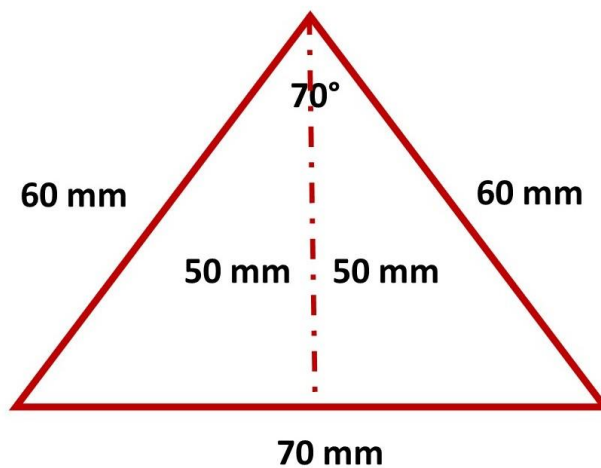

**Figure 42**

If we now put these two triangles next to each other, you get the impure fraction 22/7.

Let's add up the sizes: (6 cm x 2 =) 12 cm + (5 cm x 2 =) 10 cm = 22 cm. If we divide this by 7 cm, you have the mathematical fraction  $22/7 = 3.142\ 857\ 142\ 857 \dots$

And single triangle can also  $(6 + 5) / 3.5$  be  $11/3.5 = 3.142\ 857\ 142\ 857 \dots$

The mathematical fraction  $22/7$  is thus geometrically impure. Because if you project it in the circle pentagram, then  $70 \times 5 = 350^\circ$ . You will then be  $10^\circ$  short in the circle. So, you can see how this mathematical fraction came about. By omitting the decimals.

### **The perfect number Pi ( $\pi$ )**

If you now strive for perfection, then you adopt the perfect sizes. You can precisely calculate the measurements of the triangle that arises in a pentagram whose sides are 12 cm. The angle of  $72^\circ$  is equal to 72 mm on the opposite side, figure 43.

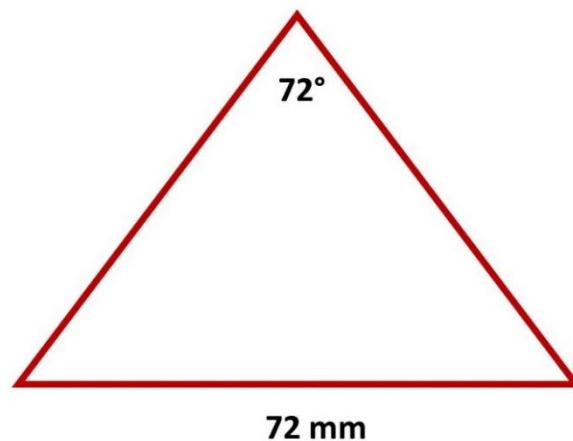

**Figure 43**

This triangle consists of two triangles in the ratio  $36^\circ : 54^\circ : 90^\circ$  ( $\sqrt{1} : \sqrt{2} : \sqrt{3}$ ). The sizes are shown in figure 44, with two decimal places.



### What else can you do with the triangle $72^\circ : 54^\circ : 54^\circ$ ?

If you determine an angle of  $72^\circ$  and set the opposite side at (72 mm) 7.2 cm, then you have the perfect triangle.

You can now start using this triangle of  $72^\circ$  as I indicated with the  $60^\circ$  triangle. If you measure 18 mm from right to left on the 72 mm line, you have an angle of  $18^\circ$ . If you measure 42 mm from right to left on the 72 mm line, you have an angle of  $42^\circ$ . See figure 45.

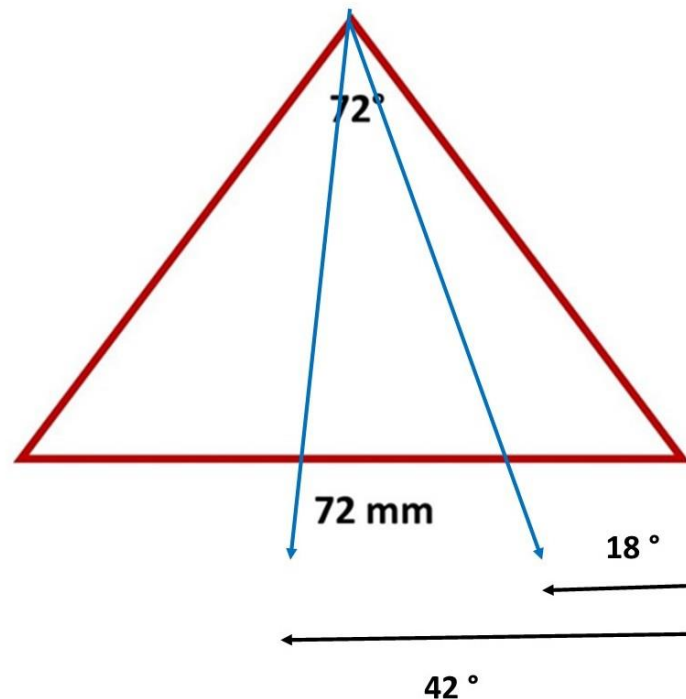

Figure 45

The opposite side of the  $72^\circ$  angle is equal to the angles of a circle.

What you can't do with this triangle is determine trigonometric calculations with it. You need a 6 cm hypotenuse side for that. The hypotenuse of the  $72^\circ$  triangle is 6.23 cm and that differs for trigonometry calculations. The pentagram with sides of 12 cm does show the ratio based on this 6 cm (6:6:6).

If you look at figure 46, you can see how this is created. The lower triangle is therefore a perfect 72° triangle with an opposite side of 72 mm. And the top triangle is a perfect 36° triangle where the opposite side is 36 mm and the hypotenuse is 6 cm, perfect for trigonometric calculations.

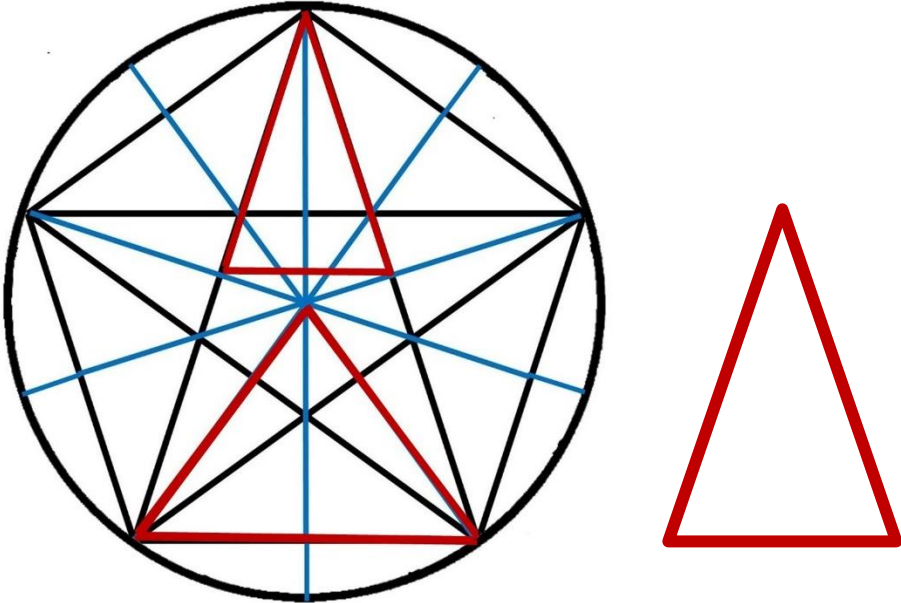

Figure 46

I give this pentagram the designation golden pentagram?





We're almost there now.

How do you determine the circumference of the circle using the pentagram? See figure 47. Suppose you have a pentagram whose sides are 1 cm. Then draw an extra line (red) of 1 cm in height, as shown in figure 17. Now determine the center of the pentagram by intersecting the line (blue) with the other line (red).

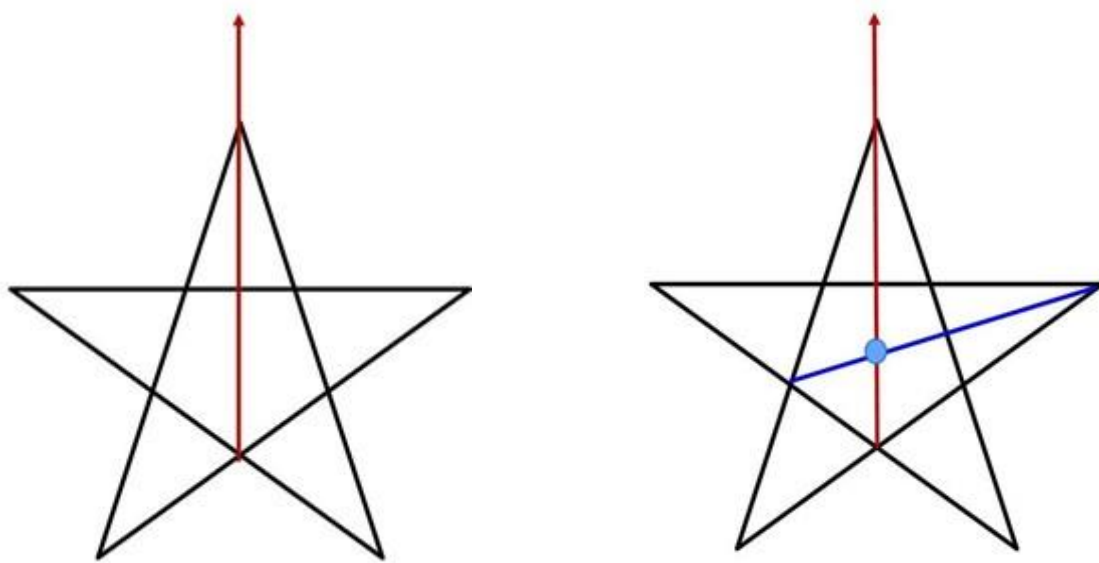
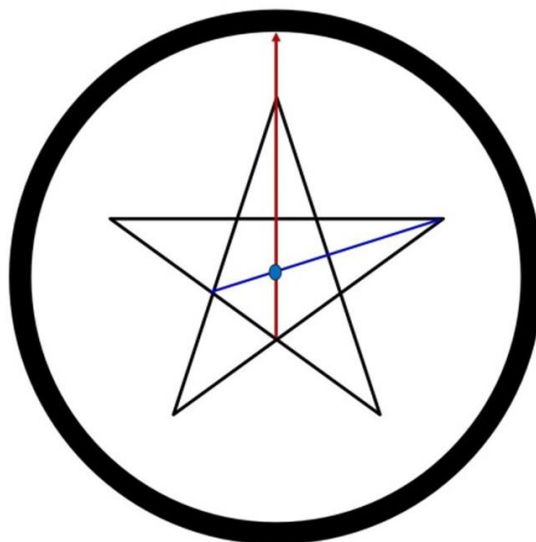

Figure 47



Now draw the circle from this center, and you have the circumference.

## Now the calculation.

You can skip all this by determining the intersection point on the 1cm line. If you are going to measure, you will arrive at about 0.8 mm.

If you now tune this to the number Pi of the pentagram, the intersection point is **0.795 mm**.

This creates a divide factor based on 1 cm of **10/7.95**.

What remains then is the line itself, which is equal to the radius of the circle as shown in figure 17.

The circumference of the circle is then determined by multiplying the radius by the divide factor and then multiplying that by 5.

$$\text{Circumference} = R \times 10/7.95 \times 5$$

Suppose the radius (R) is 0.5.

$$\text{Then the circumference without Pi calculation is: } 0.5 \times 10/7.95 \times 5 = 3.144$$

$$\text{The circumference in relation to the number Pi is then: } R \times 2 \times 3.14 = 3.14$$

Everything that is inside the pentagram is now indicated.

Don't underestimate the pentagram, it's a mathematical gem.

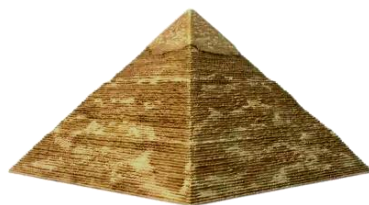

Everything is related to the pyramid, where the triangle in the ratio  $\sqrt{1} : \sqrt{2} : \sqrt{3}$  comes from, where the calculation of trigonometry comes from and how essential the ratio **6:6:6** is.

## The angle of 54°.

The triangle  $\sqrt{1} : \sqrt{2} : \sqrt{3}$  has, in addition to the pentagram angle of 36°, also an angle of 54°. What can you do with this?

With the angle of 54° you can make different calculations and determine triangular relationships. I'm going to explain this. We start with the triangle determination.

We now know that for an isosceles triangle whose apex angle is below 60°, the opposite side is equal in mm, if the hypotenuse is 6 cm.

Figure 48 then shows, if the apex angle is 54°, that the opposite side is 54 mm or 5.4 cm. In this case the height is also equal to the angle in mm (54). You now see two triangles in the ratio 1 : 2 :  $\sqrt{5}$  coming forward ( $2.7 \times \sqrt{5} = 6$  cm).

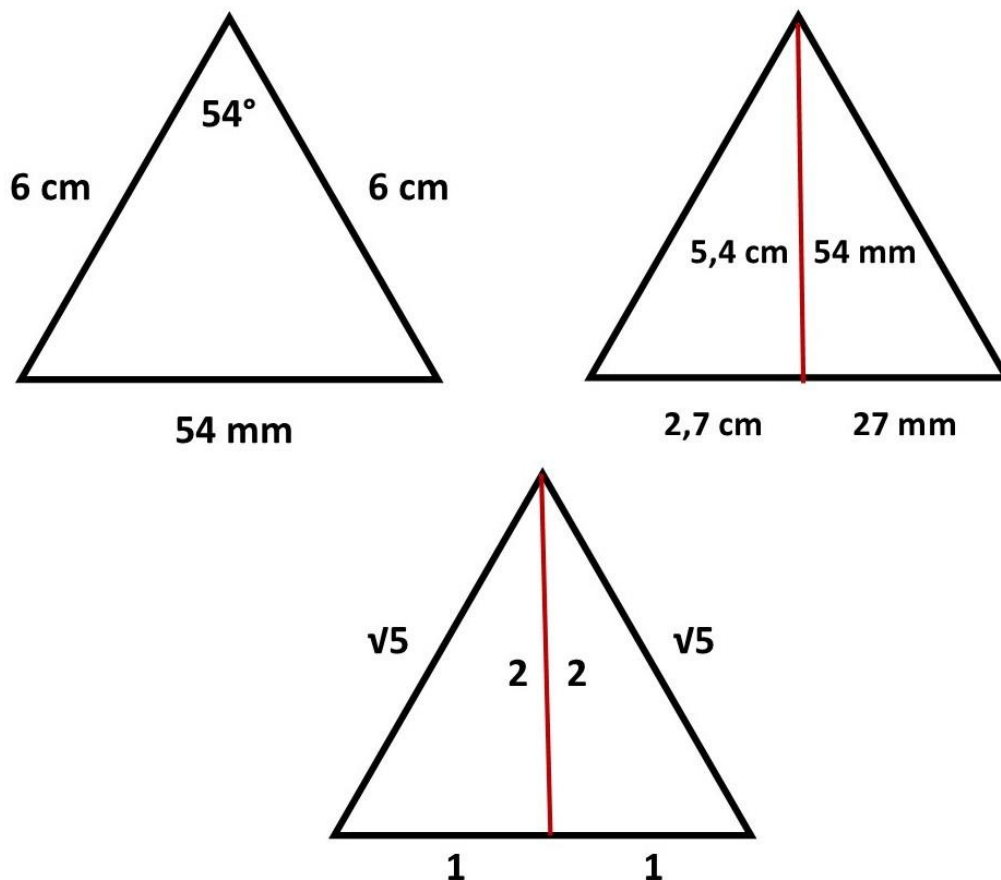

Figure 48

This indicates that if you have a triangle whose straight sides are in the ratio 1:2, the hypotenuse is always  $\sqrt{5}$ .

You can compare it with the right triangle 1:2:  $\sqrt{3}$ , where the largest rectangular side is always  $\sqrt{3}$ .

What else can you do with it and why is the  $54^\circ$  angle important in the pyramid?

This has to do with the square base on which the pyramid is built and designed. The ratio 6:6:6 is again essential. In the case, of the square base this means 6:6:6:6.

***I am going to show you that you can also calculate the number Pi  $\pi$  and the circumference of a circle from the square.***

We are going to start and draw a 6 cm square, see figure 49.

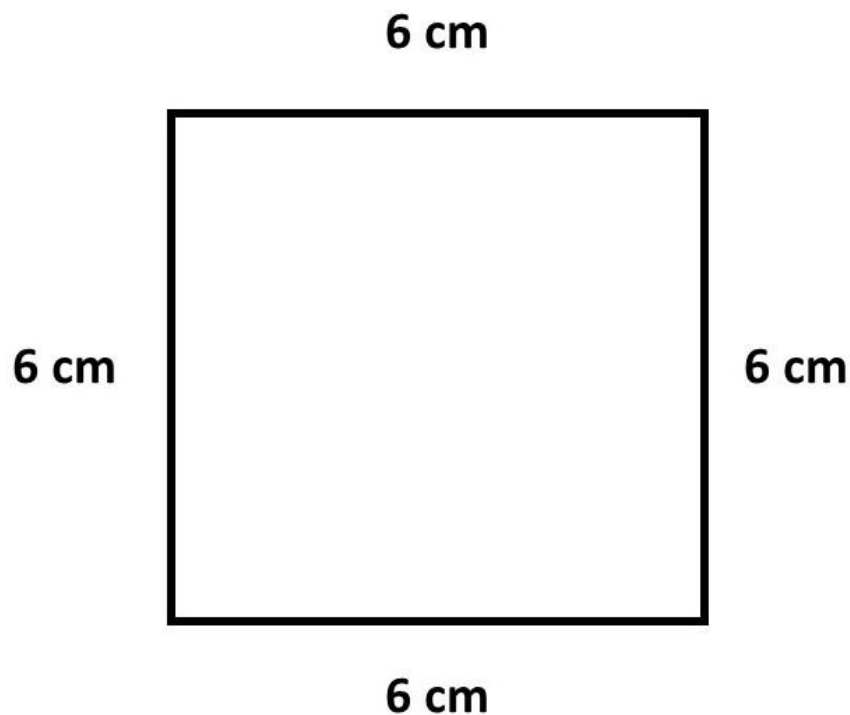

Figure 49

Now realize that the 54° angle is essential here.

I'm going to explain that in a moment.

Figure 50 shows that the diagonals of the square are  $6 \times \sqrt{2} = 8.485 \dots$  cm. Two diagonals makes  $2 \times 8.485 \dots = 16.970 \dots$  cm.

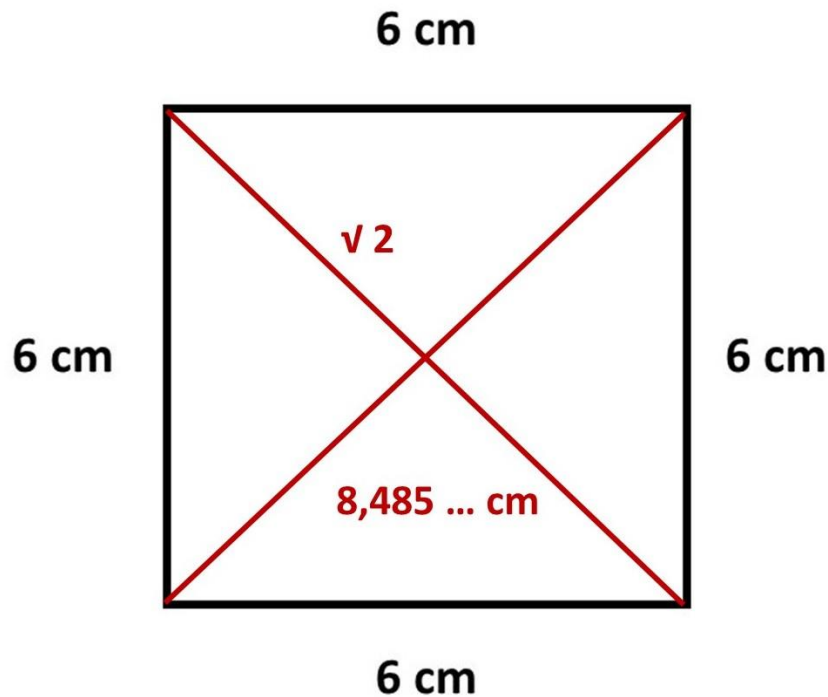

Figure 50

How do the diagonals relate to the circumference of the square. This is dividing circumference by the sum of the diagonals.  $24 / 16.97 = \sqrt{2}$ . The sum of the diagonals  $\times \sqrt{2} =$  circumference of the square.

Now the question is how does all this relate to the circle?

For this we are going to change the shape of the square.

We are now going to pull the square out of its shape and make it into a rhombus, at angles of 54°, see figure 51.

What is this based on?

If you draw an angle from a center of one side of any square to the opposite ends of the opposite side, the angle is always 54°. See figure 51.

So, you see how the 54° angle takes shape within the square. It also shows you its connection to the 54° rhombus.

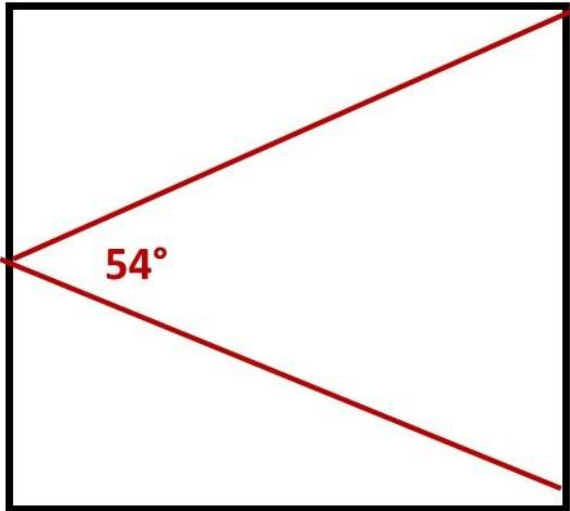

Figure 51.

We now turn the 6 cm square into a 6 cm rhombus at an angle of 54°, see figure 52.

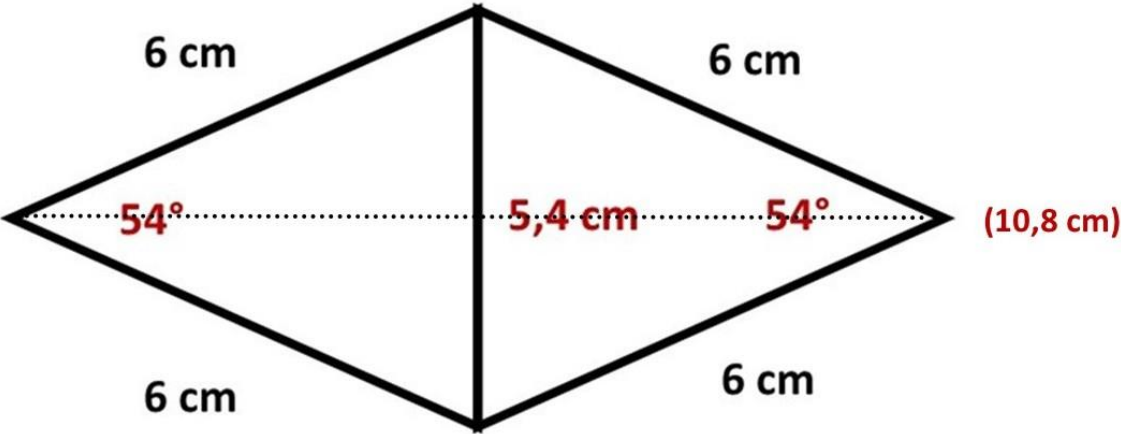

Figure 52

**The vertical diameter is 5.4 cm and the long diameter is 10.8 cm.**

*It is now the intention to determine the relationship between the diameters. This is  $\sqrt{2}$ .*

*Because  $5.4 \text{ cm} \times \sqrt{2}$  (7.636) is equal to  $10.8 \text{ cm} / \sqrt{2}$  (7.636).*

*We are now going to determine the number Pi in the rhombus. We are going to divide the circumference by the centerline,  $24 / 5.4 = 4.44444 \dots / \sqrt{2} = 3.14269680 \dots$*

When we know this, we will return the rhombus to the original square

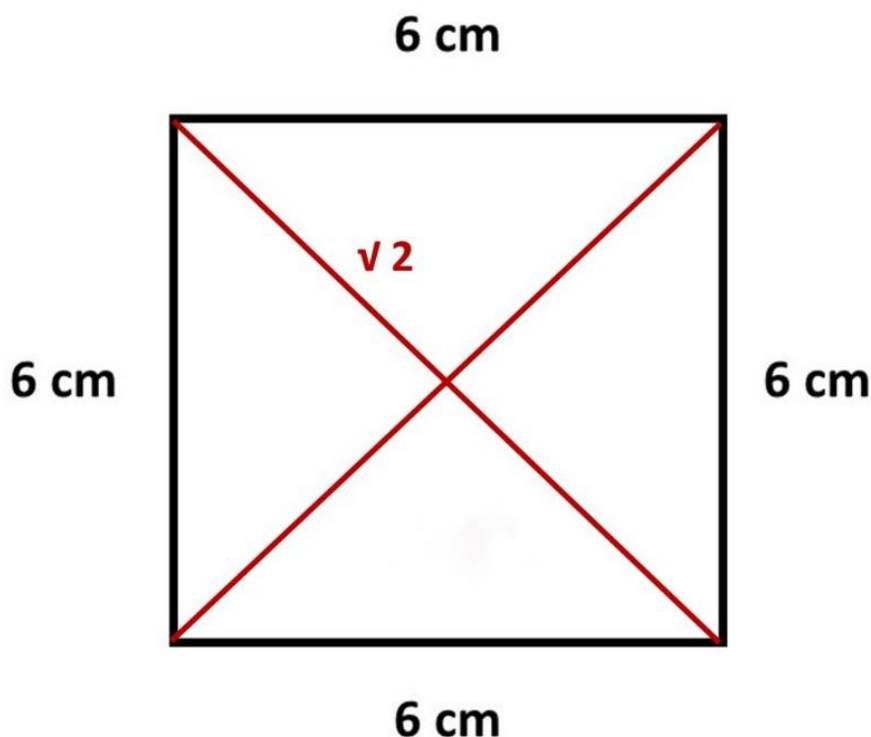

Figure 53

*How do we calculate the number Pi in this square, figure 53?*

*We do this by dividing the circumference (24) by  $5.4 = 4.444444 \dots / \sqrt{2} = 3.14269680 \dots$*

*The circumference of the square is  $\pi \times \sqrt{2} \times 5.4 = 24 \text{ cm}$ .*

Suppose we have a square with a circumference of 36 cm (4 x 9 cm). Then simplify again to 24 cm.  $36/24 = 1.5$ . We will then increase the diameter of 5.4 cm by a factor of 1.5.

***The circumference of the square is then  $\pi \times \sqrt{2} \times (5.4 \times 1.5) = 36$  cm.***

***How does this relate to the relationship with the circle?***

***The circumference of the square is  $\pi \times \sqrt{2} \times 5.4 = 24$  cm.***

***$\pi \times (\sqrt{2} \times 5.4) = 24$  cm***

***$\pi \times 7.64 = 24$  cm***

***Diameter / 7.64 x 24 = circumference circle.***

***(5.4 cm x  $\sqrt{2}$  (7.636) = rounded to 7.64)***

***Suppose we have a diameter of 28 cm, what is the circumference?***

***We now have three options.***

***The pyramid method.***

***Diameter x  $\pi = 28 \times 3.14 = 88$  cm (rounded).***

***The pentagram method (14 / 0.795) x 5 = 88 cm (rounded).***

***The square method (28 / 7.64) x 24 = 88 cm (rounded).***

What else can we do with the 54° triangle in the square?

We can as we do this with the equilateral triangle of 60°, and the triangle of 72° also plot the angles on a circle with the square.

I will explain this to you based on a 9 cm square.

The ratio 9:9:9:9.

You will then see again how important the 54° angle is.



## The square of 90 mm - 9 cm.

A square has four  $90^\circ$  angles. Four sides of 90 mm complete the circle, you could say. But how do you do that?

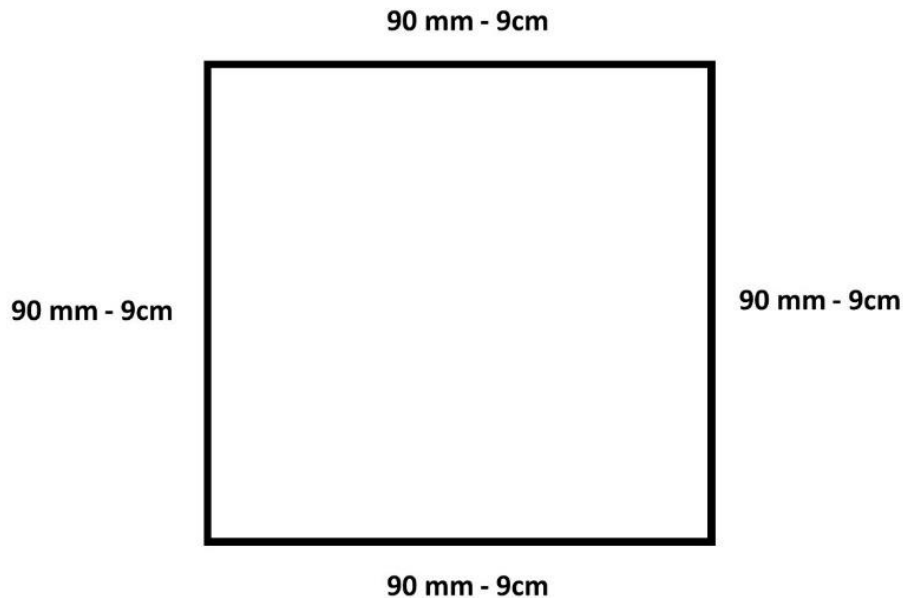

We start by making a square of 90 mm = 9 cm. We determine the center of a line = 4.5 cm and draw two lines from that center to the opposite corners, see figure 54 below.

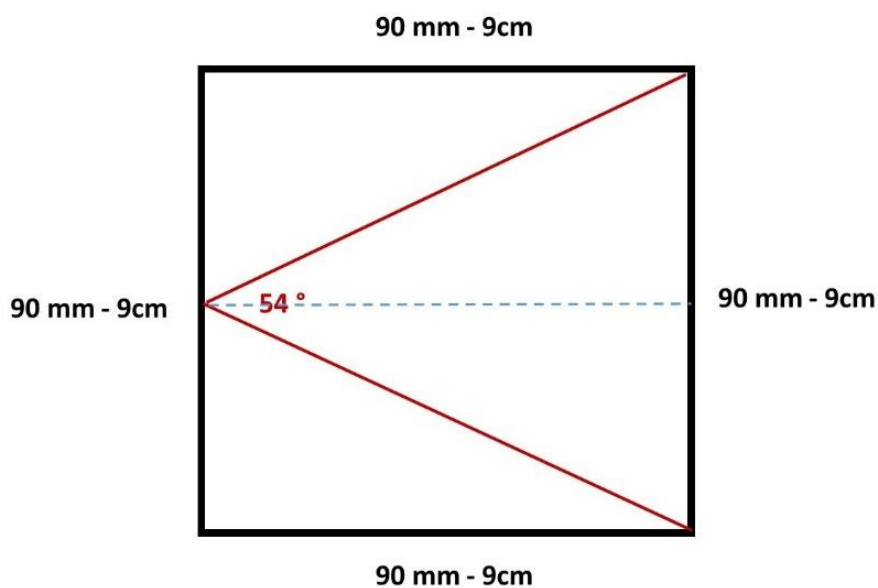
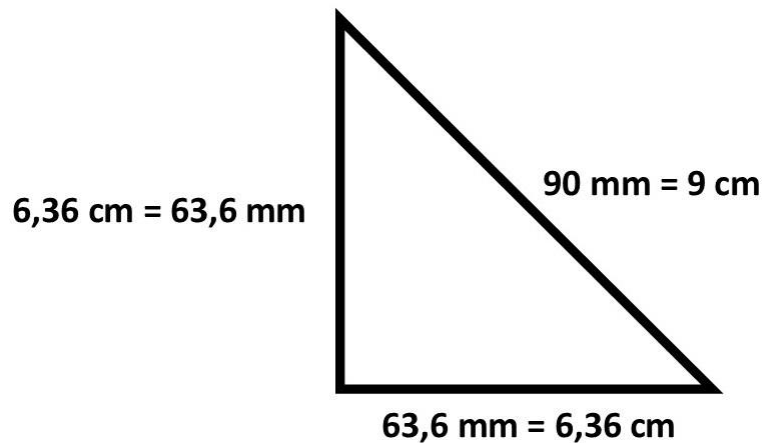

Figure 54

We have now created an angle of  $54^\circ$  (2 triangles in the ratio  $1 : 2 : \sqrt{5}$  next to each other)

It is now the intention to determine an angle on the circle from a  $90^\circ$  angle (in the ratio  $1 : 1 : \sqrt{2}$ ) without using a protractor.



Next we determine the center of the square and draw a circle around the square, see figure 55.

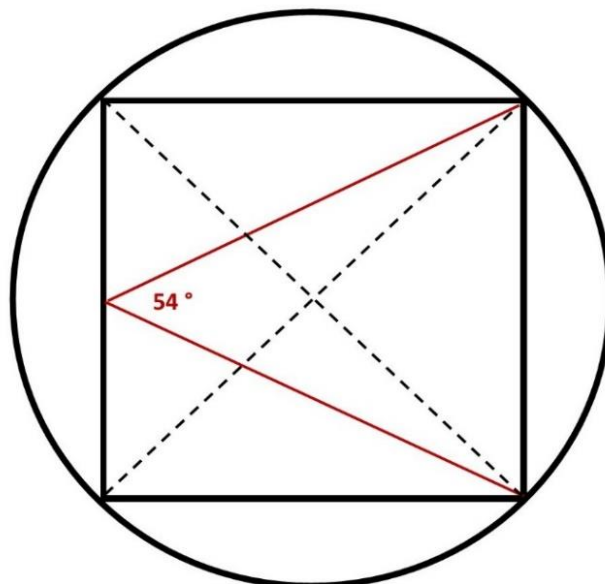

Figure 55

Suppose we want to have an angle of  $25^\circ$ .

Then we set off 25 mm (point C) on the straight line A-B (90 mm), see figure 56. Then we draw a straight line from the 54° angle through point C to the circle (circle point).

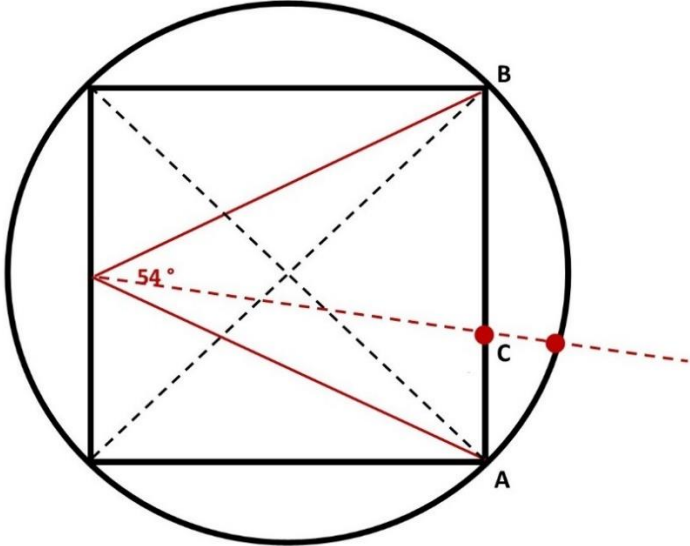

Figure 56

Then draw a straight line from the center M to the circle point, see figure 57. **Angle A - M - D = 25°**

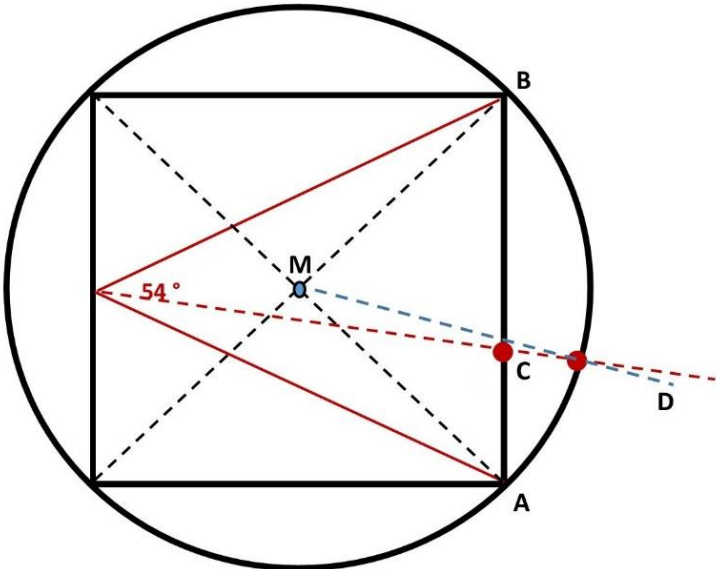

Figure 57

Suppose you want an angle of  $75^\circ$ . Then set off 75 mm (point C) on the straight line A-B (90 mm), see figure 58. Then we draw another straight line from the  $54^\circ$  angle through point C to the circle (circle point). Then again draw a straight line from the center M to the circle point. **Angle A - M - D =  $75^\circ$**

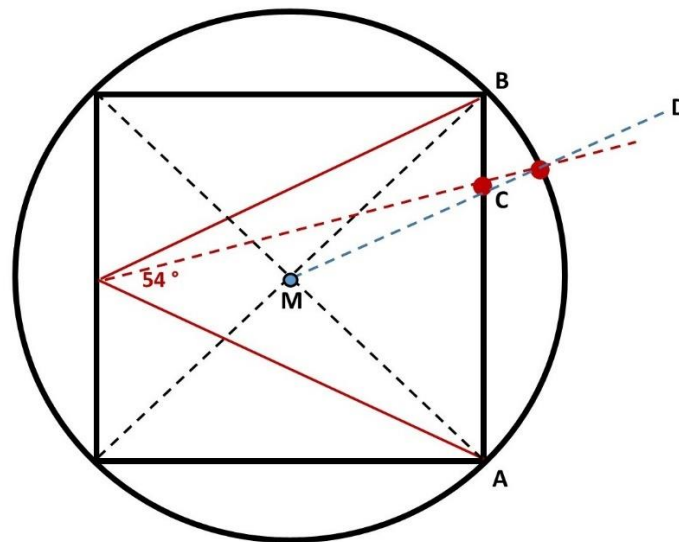

Figure 58

In this way you can determine any angle from the 9 cm square, see figure 59.

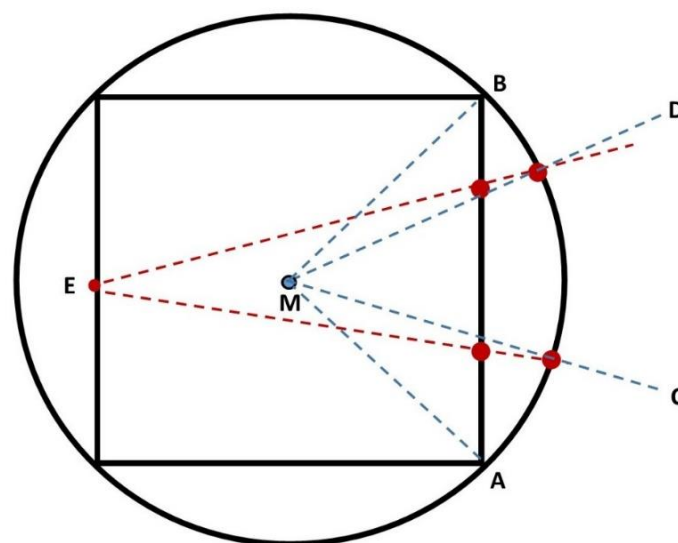
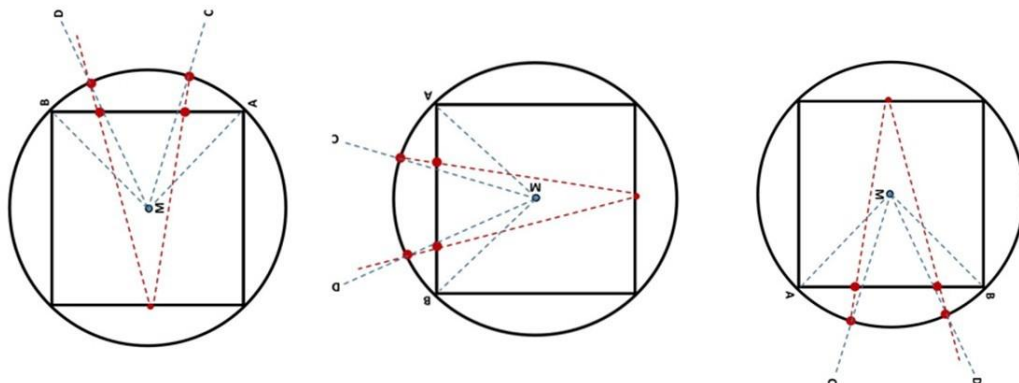

Figure 59

You can project this on any 90° line (90mm - 9cm). And that completes the circle.



***If you are now going to draw a square of 12 cm, the angles will not be correct. Then you get again what I described with the equilateral triangle. You will then have to reduce the 12 cm to the 9 cm ratio.  $12/9 = 1.33...$  This means that the angle measurements on a 12 cm square must be increased by a factor of 1.33 ....***

We now move on to the Great Pyramid on the Giza plateau in Egypt.

***Why is it unique and separate from the other Egyptian pyramids built after it.***

***The reason is that it is intended as a Geometric standard.***

Now many will question this because it is said that the Great Pyramid is a burial monument of Cheops, which is the only one with shafts on the inside. These shafts are dismissed as 'shafts without further meaning'. Cheops was never found in it. All this shows total ignorance.

Which architect who strives for perfection is just going to make shafts in a pyramid without meaning for the 'fun'? So, it seems totally unlikely to me.

It is ignorance that downplays the perfection of the Great Pyramid to a simple funerary monument.

I now show you the cross-section of the pyramid and have given the shafts meaning as they are intended, figure 60.

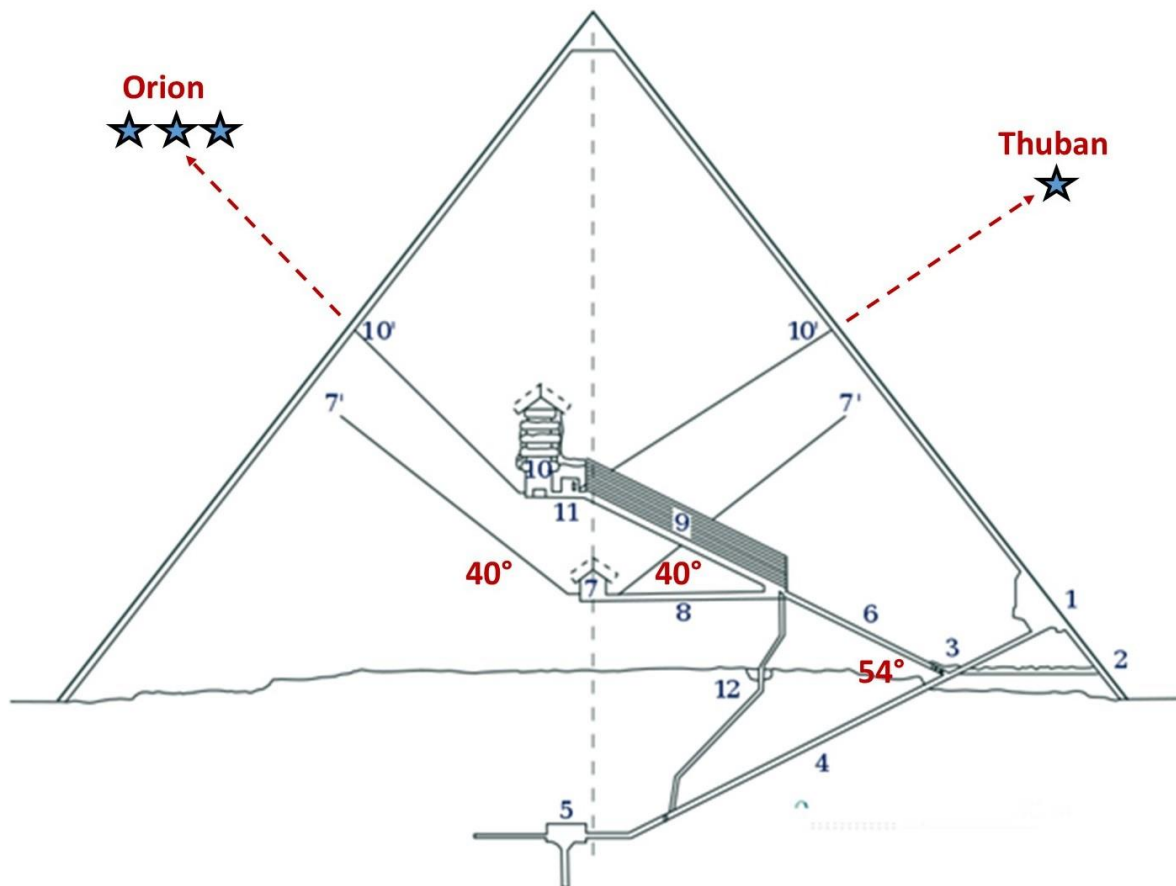

**Figure 60**

I have explained the geometry of the pyramid regarding the construction plan of 4 equilateral triangles of  $60^\circ$  and the square base, both in the ratio 6:6:6 and 6:6:6:6.

If you look at the shafts and corridors, you can see the angles at which they were built. The entrance angle 3,4,6 is at the angle of  $54^\circ$ . So, I have already explained to you what this angle of  $54^\circ$  in the square base means. You see how the half geometric rhombus reveals itself.

The shafts 7 are very special. They are in the building plan at angles of  $40^\circ$ . What can you do with this now? The  $40^\circ$  angle is connected with the Enneagram, or nine-star.  $9 \times 40^\circ$  completes the  $360^\circ$  circle. The number 9 symbolizes the 9 numbers we work with, and those 9 numbers are at the base of consciousness. Everything in the development (logic, understanding and knowledge) of man can be traced back to the 9 numbers and the (spoken) Word.

*Following the Word, I want to describe a Biblical quote from John (John's gospel).*

*In the beginning was the Word, and the Word was with God, and the Word was God. All things were made by the Word, and without it nothing was made that was made.*

So, this indicates that as human beings we have created (named) everything ourselves and therefore we have created our own reality (our own world view). I doubt very much whether this is a good world view, if you look at the world of 2022.

The  $40^\circ$  angle is associated with the number 9.

Now draw an isosceles triangle with an apex angle of  $40^\circ$ . Divide the  $40^\circ$  by 9. Then you get the height of the isosceles triangle.  $40/9 = 4.444444\dots$ . If you now divide this result by  $\sqrt{2}$ , you get the number  $\text{Pi } \pi$ , 3.142696 ... This is the opposite side of the  $40^\circ$  angle. The oblique sides of the triangle are then together  $\text{Pi } \pi$ , 3.142696 ...  $\times \sqrt{9} = 9.428 \dots$  Rounded off 9.43 cm. Is 4,715 per side.

This indicates that the  $40^\circ$  triangle represents the number  $\text{Pi } \pi$  and the circumference of the circle. This number  $\text{Pi } \pi$  is equal to the number  $\text{Pi } \pi$  of the square.

So, the basis of this is  $24/5.4 = 4.4444 \dots$  and  $40/9 = 4.4444 \dots$

You can now ask yourself how do I get this? The  $54^\circ$  angle is described in the square. What about the  $40^\circ$  angle?

I'm going to make a sidestep for this. There are two unique pyramids (connected to each other) whose meaning is unknown in this modern age 2022. They are the Great Pyramid on the Giza plateau in Egypt and the Pyramid of the Jaguar in Tikal Guatemala. This last pyramid is (if you study the building plan) built under these dimensions.



**Pyramid of the Jaguar**

Here too, this pyramid is again labeled as a grave monument. So, you can clearly observe that mathematics (geometry) does not go hand in hand with archaeology.

It is stated that the height of this pyramid is near 44 meters. The ground plane is between 30 and 32 meters. If you measure the exact measurements, you will never know the deeper meaning of this pyramid. This pyramid has also been subject to decay, subsidence, etc. for centuries. Seems logical to me.



Therefore, again like the Great Pyramid, look for - and study the building plan that precedes it, figure 61.

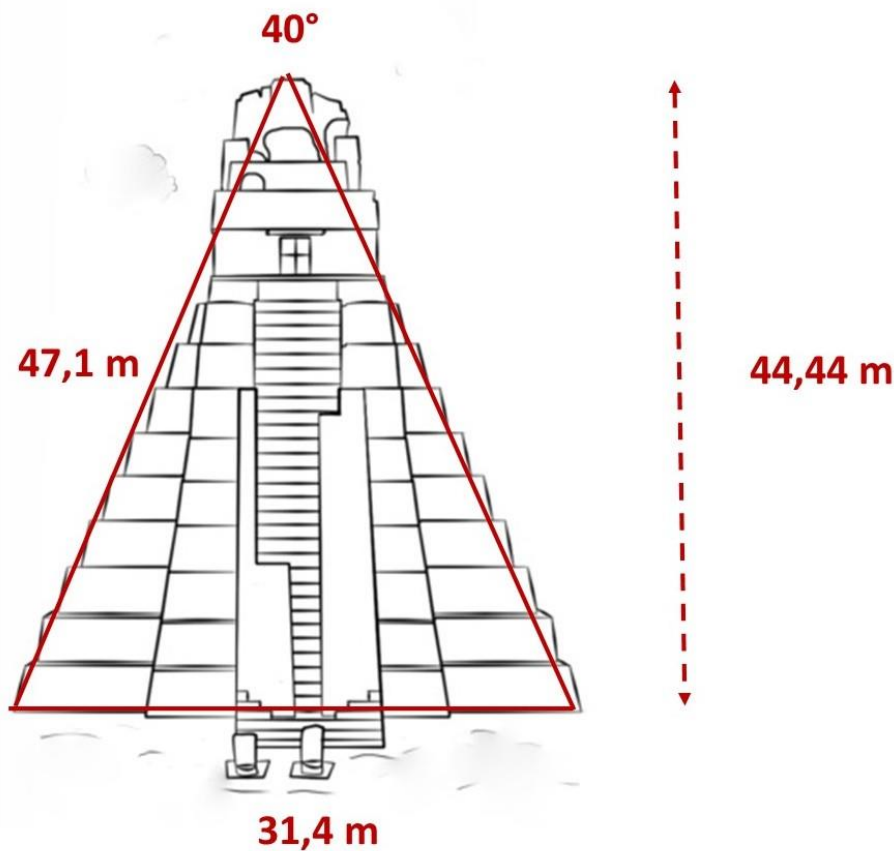

Figure 61

So, the pyramid of the Jaguar represents the circle. The number Pi  $\pi$  is given and also the circumference of the circle. The factor diameter is then again  $\sqrt{9} = 3$ .

$$(47.1 \times 2 = 94.2 / 31.4 = 3)$$

***Diameter x Pi  $\pi$  = circumference.***

More precisely, you can calculate it by dividing the 40° angle by 9. Dividing the result by  $\sqrt{2}$  (= Pi  $\pi$ ) and multiplying that result again by  $\sqrt{9}$  (circumference).

So, the pyramid of the Jaguar represents the circle. The number Pi  $\pi$  is given and also the circumference. The factor diameter is then again  $\sqrt{9} = 3$ . What you still need to know is how I get the sizes  $\sqrt{2}$  and  $\sqrt{9}$ ?

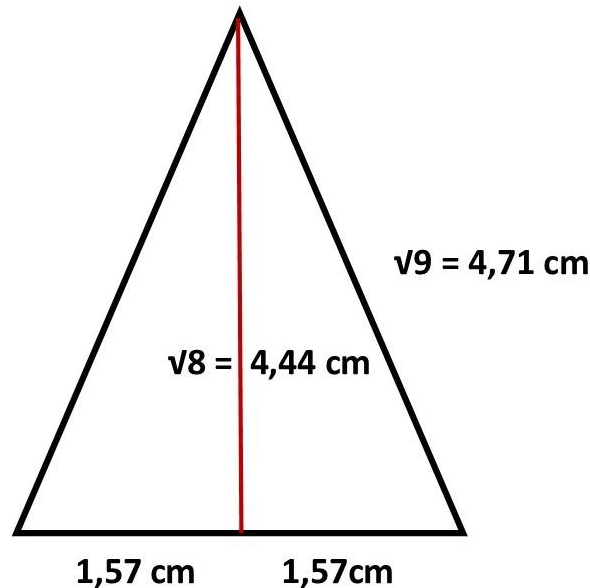

Figure 62

Figure 62 shows this. If you make a rectangle of the  $40^\circ$ , you can see how this is created. If you are going to put the two right triangles back together, then  $\sqrt{8} - \sqrt{2}$ . How do you calculate the circumference based on what you see in figure 62. ***Diameter  $\times 40 / 9 \times \sqrt{2}$*** . Suppose the diameter is 15 cm. Then, according to the way we know, that is  $15 \times 3.14 = 47.1$  cm. However, you do not know where this number 3.14 comes from. So, it is made up of the triangle of  $40^\circ$ . Figure 62. ***Circumference =  $15 \times 40 / 9 = (x) / \sqrt{2} = 47.1$  cm.***

With compared to the number Pi, you can now geometrically demonstrate and determine 4 Pi numbers:

- ***The pyramid number:  $\sqrt{2} + \sqrt{3} / \sqrt{1} = 9.43 / 3 = 3.143333333 \dots$***
- ***The pentagram number:  $22.64 / 7.2 = 3.144444444 \dots$***
- ***The square number:  $24 / 5.4 / \sqrt{2} = 3.14269 \dots$***
- ***The  $40^\circ$  angle number.  $40 / 9 / \sqrt{2} = 3.14269 \dots$***

We are now going to look at the outside of the Pyramid, figure 63.

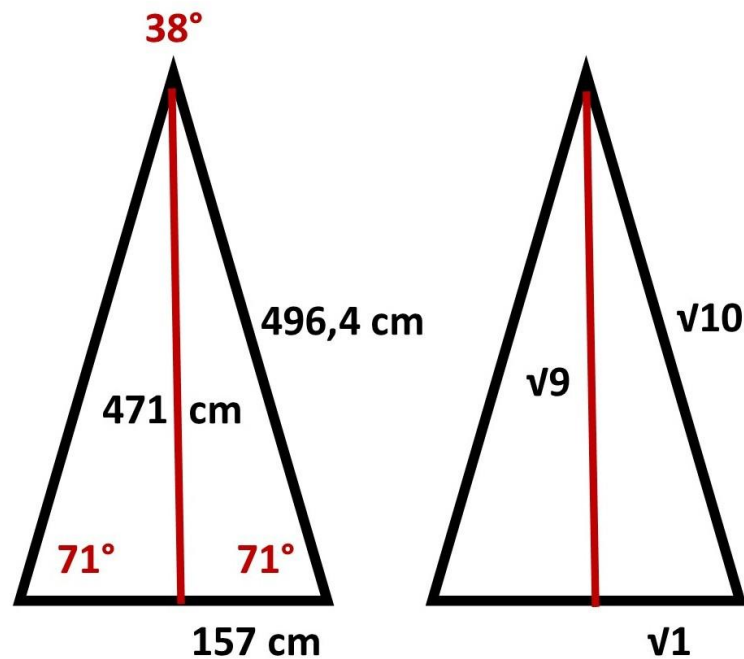

Figure 63

The hypotenuse C ( $v9$ ) of the inside now becomes side B ( $v9$ ) on the outside because we always work with straight lines, see figure 63. The hypotenuse is then 496.4 cm on the outside.

If you now divide the hypotenuse C by side A 157 cm, you arrive at ( $v10$ ). There are always (negligible) decimal deviations when working with decimals. Side A 157 x side C ( $v10$ ) = 496.4 cm (figure 63).

You can see how perfectly the Pyramid of the Jaguar in Tikal is built.

How do you know that the apex angle on the outside is  $38^\circ$ ? I have already explained that in the trigonometric ratio.

You are going to return side C of the triangle to the standard 6.  $496.4 / 6 = 82.73$ . Then you reduce side A by a factor of 82.73.  $157/82.73 = 1,897$ . This x 2 =  $3.795 \times 10$ . Rounded off  $38^\circ$ .

Since one worked with square root ratios, I could therefore easily determine the theorem  $A^2 + B^2 = C^2$ .  $\sqrt{1^2} + \sqrt{8^2} = \sqrt{9^2}$  ( $1 + 8 = 9$ ). It should be noted that in the current modern age 2022 every person has a calculator (on the telephone or PC). It is then easy to make calculations. However, what was it like in a time when people did not have these calculators and had to calculate everything themselves on paper?  $A^2 + B^2 = C^2$  was fine but often intensive. Therefore, standard triangles were created that made it easier to calculate sides. In our modern times we know the standard triangle  $30^\circ : 60^\circ : 90^\circ$ , in the ratio  $1:2:\sqrt{3}$ . If the hypotenuse C is to side A in the ratio  $2:1$  then side B is ( $A \times \sqrt{3}$ ). That also applies vice versa. If the straight side B has a ratio of  $2:1$  to side A, then side C is ( $A \times \sqrt{5}$ ).

The Pyramid of the Jaguar shows us two other standard triangles. So, the first standard triangle is on the inside. If the hypotenuse C is related to side A in the ratio of  $3:1$  then the straight side B is ( $A \times \sqrt{8}$ )

Then the outside. If the straight side B is related to side A in the ratio of  $3:1$  then the hypotenuse is C ( $A \times \sqrt{10}$ ).

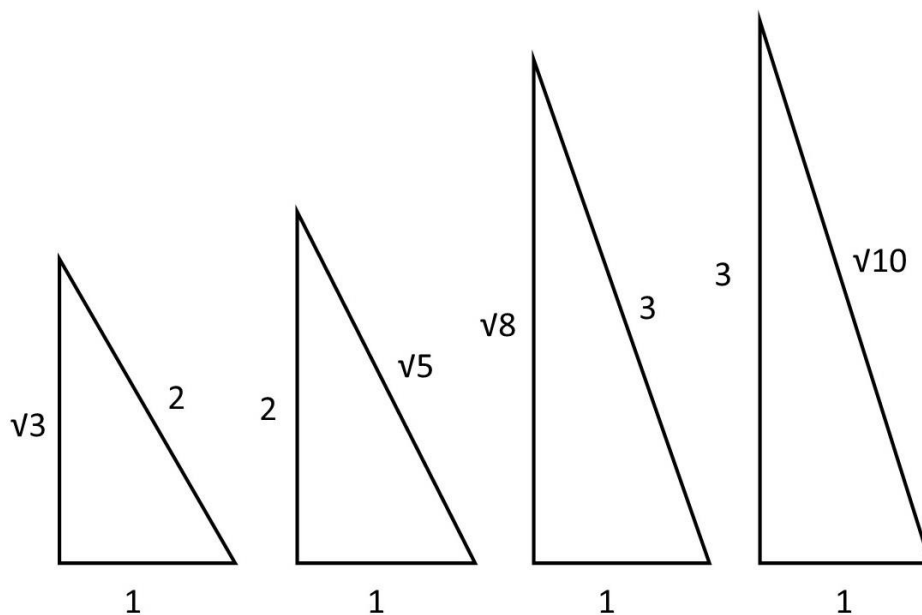

**Figure 64**

The first two proportions (figure 64) are based on the Great Pyramid of Giza and the last two on the Pyramid of the Jaguar at Tikal. All in all amazing don't you think?

The Pyramid of the Jaguar exudes perfection. It is made up of a square base in the ratio of  $4 \times \pi$ , and triangle sides in the ratio  $\sqrt{8}:\sqrt{9}:\sqrt{10}$ .

What else can you find in the Pyramid?

As I mentioned earlier at the Great Pyramid of Giza, a circle is designed by means of an equilateral triangle in the ratio 6:6:6. If you put six equilateral triangles together, you get the perfect circle where the angles are equal to straight lines in proportion to the equal angles on the circle.

How are things at the Pyramid of the Jaguar in Tikal?

So you have given a triangle of  $40^\circ : 70^\circ : 70^\circ$ , see figure 65.

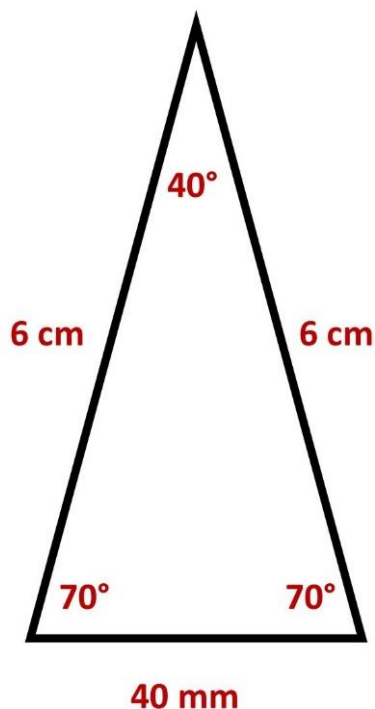

In a triangle in the ratio  $40^\circ:70^\circ:70^\circ$ , the opposite side of the  $40^\circ$  angle is 40 mm and equal to the angles of a circle, if the two hypotenuses are 6 cm.

Figure 65

So, if you know this, you can easily determine the angles of a circle without needing a protractor. But even more important is how to design a 360° circle. How do you do that? Imagine, you don't have a standard 360° circle yet. How are you going to extend 360 equal lines on the circle from the center that are all 1 mm apart? You also don't have a protractor because you can't design it until you've designed a circle, then you can only match a standard jig (protractor) to it. See a (blank) circle below. How can you now plot 360° on this (blank) circle from the center?

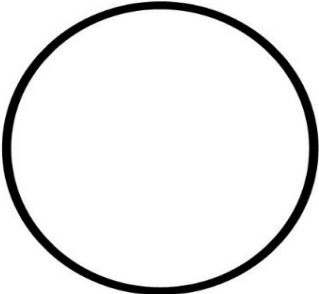

You do this by placing 9 triangles in the ratio 40° : 70° : 70° with hypotenuses sides of 6 cm next to each other, as shown in figure 66.

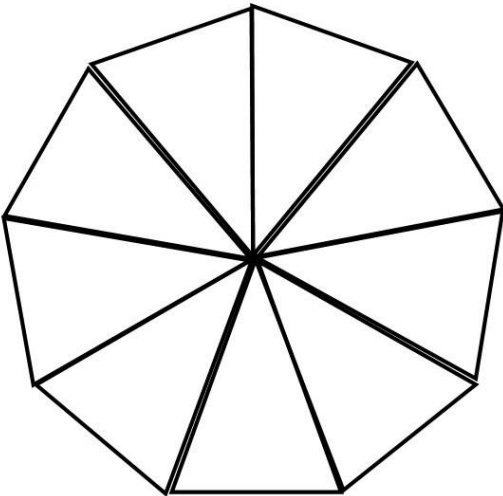

Figure 66

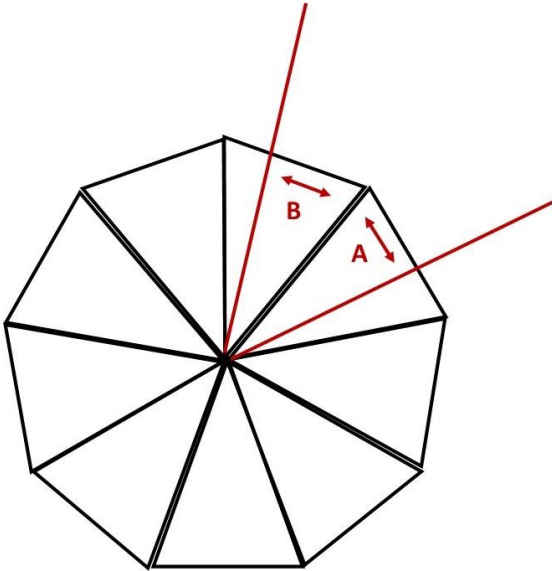

Figure 67

You now have a nine-angle,  $9 \times 40$  mm which is equal to  $9 \times 40^\circ$ . You can then continue 360 lines on the circle. How do you determine the degrees in the nine-angle? Suppose you want an angle of  $55^\circ$ . For example, you plot an arbitrary line to the right, see figure 67. Then determine 55 mm to the left or right (left or right) according to straight lines. Then you have an angle of  $55^\circ$  that is equal to the  $55^\circ$  angle of the circle.

An important fact about the Pyramid of the Jaguar is that it consists of nine layers on the outside. These nine layers have cosmic significance, as is the case with the Great Pyramid of Giza. The number 9 was an important number. It stands for the Enneagram, see figure 68.

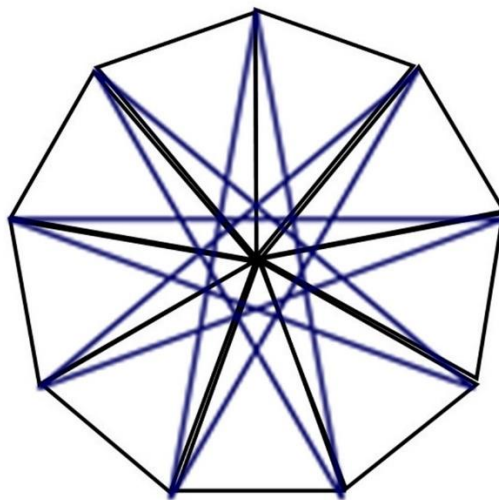

Figure 68

The Enneagram symbolizes the nine numbers that make up everything. Nine numbers that are at the cradle of our consciousness, have magnified our logic, views, and connections. Nine numbers that stand at the cradle of our development. You can say that 9 is a sacred number. Because if there were no numbers, how would we be as human beings do you think?

## What the sun, the moon and the stars teach us.

I have already shown you that the upper shafts in the Great Pyramid of Giza in Egypt face the stars. They are aimed at the stars, Orion's belt and the star Thuban (Constellation Ursa Major). They are specially designed to determine the North and to determine the time. I'll come back to this later.

At the Pyramid of the Jaguar, time is determined by the Sun, see figure 69.

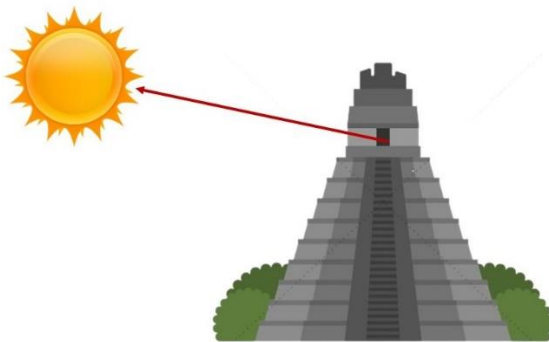

Zon

Figure 69

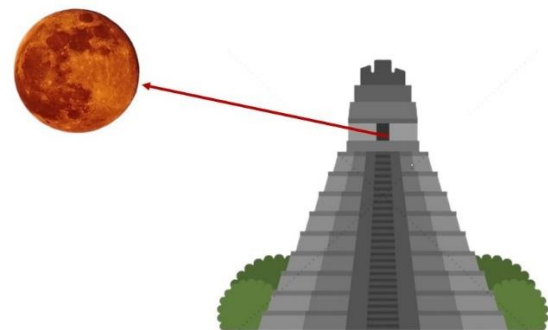

Maan

Figure 70

By taking a position in the top room and looking out the open window, you can look up the sun **on any given day, at any time**, so that it is projected all the way around the window. **You should mark this day and this moment.** Because after about three days, the sun has disappeared from the marking point (in projection). He then comes back at exactly the same point after a year. If you want to determine the rotation of the Earth around its own imaginary axis (a day), you do the same.

After three days the sun is out of focus to return to the window after 365 days - the highlight position.



You can also do this with the Moon (full Moon), see figure 70. You can then see in how many days the Moon revolves around the Earth.

Now you can question this, but the proof is given a little further down in Mexico, see figure 71 and figure 72.

### The secret of the shadows.

Figure 71 shows the El Castillo Pyramid in Chichén Itzá Mexico. It has no mathematical meaning. He does show how you can build under the shadow of the Sun.



Figure 71

On December 21 (winter solstice) each year, the Sun is positioned to completely obscure the far side, see figure 72.

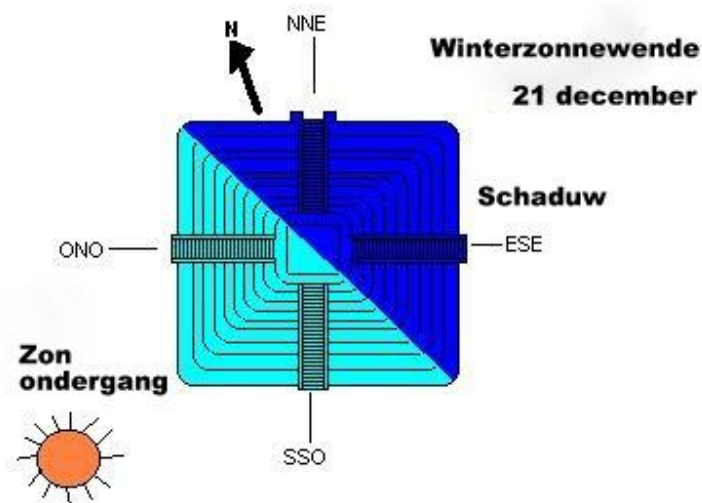

Figure 72

This proves all the foregoing, regarding solar time and sidereal time.

The only thing you have to 'hand over' is **the day and time of the sighting (marking)**. And that is no longer known compared to the Pyramid of the Jaguar in Tikal Guatemala and also not with the Great Pyramid of Giza Egypt.

The Pyramid of the Jaguar in Tikal Guatemala is as much of a mathematical gem as the Great Pyramid of Giza in Egypt. They are both unique in their existence and their relationship to each other is unknown until now.

*The building plans are located inside the Pyramids, you just need to find them.*

**We now go back to the Great Pyramid of Giza Egypt.**

The section of the Great Pyramid, figure 60, shows the two shafts built at an angle of  $40^\circ$ . You will not know the mathematical value of these shafts if you do not know the story of the Pyramid of the Jaguar in Tikal Guatemala. Or as an architect you must have written it down somewhere. However, you need the building plan for that.

The top two shafts face the stars. All shafts are closed in the Great Pyramid except for these two see-through shafts.

The star Thuban was 2800 BC. the pole star (North). Today that is the star Polaris (North). Thuban thus determined the construction towards the North of the Great Pyramid.

The other shaft faces Orion's belt. And this determines the time and the calendar. How do you determine time on Earth now? How do you determine years, months, weeks, days, hours, minutes, and seconds?

*I explain to you in a simple example how you can determine the sidereal time, every day, and how you can determine the year and how you can determine the calendar.*

All you need is a simple wooden slat about 3 meters high. Make a round hole at the top of the wooden slat and stuck the other side vertically and straight into the ground, figure 73.

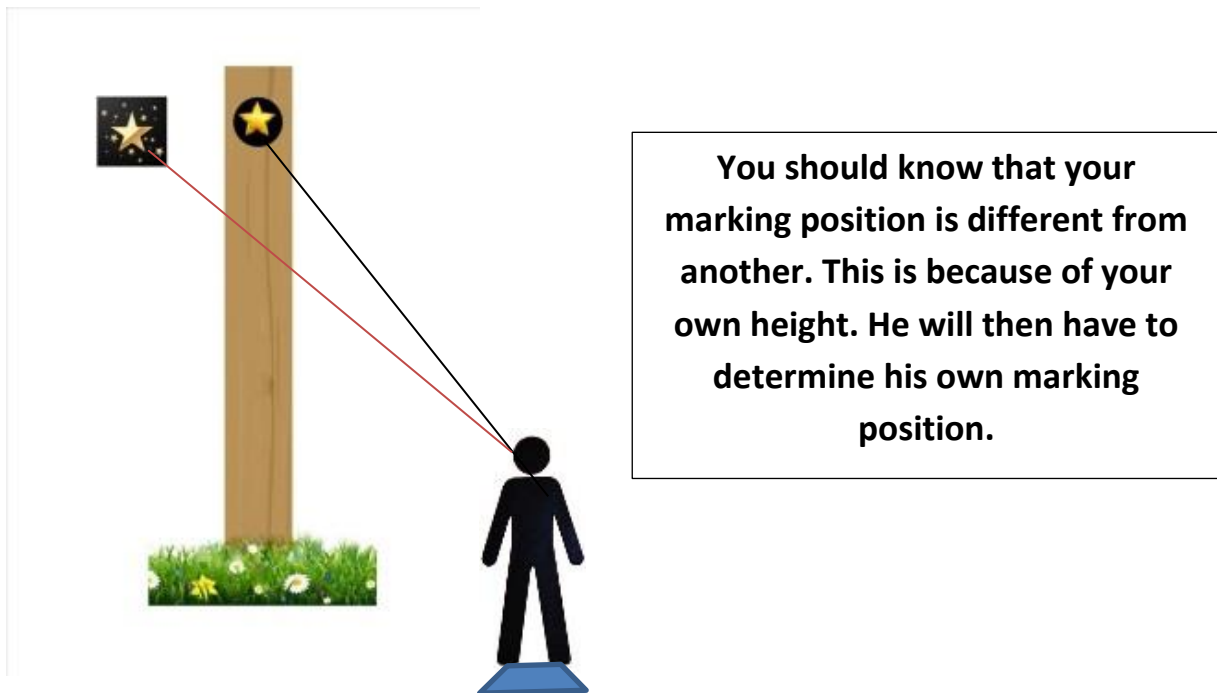

**Figure 73**

Now wait until the evening or night falls, the best is with a clear starry sky. Look for a bright star in the darkness and position yourself on the ground so that you can see the star in the round hole of the wooden slat. Then stand straight. A little later you see that the star disappears from the hole because the Earth simply moves in the Universe. Then immediately mark the place where you stand and leave the wooden slat where it is. Then it gets light again, and the day begins. When night falls again and darkness falls, look for the star you saw yesterday.

Then take the marked position, stand up straight and look through the hole of the wooden slat. You will see that the star will slowly start to manifest itself again in the center of the hole of the wooden slat. Then you know that the Earth has revolved around its own imaginary axis. On Earth, this indeed corresponds to 24 Earth hours. Every person can test and investigate this for themselves on a daily basis. This is also possible the second day. Unfortunately, the third day is over. The reason is that the Earth is moving. You can then find another star and test it again.

How do you determine a year? Easy. Leave the wooden slat in place and if the star goes out of focus after a day or two then you wait a year. Then go outside the 360th day and see where the star is. Take a fixed star. My suggestion is to take the middle star of the Orion's belt or a star from the Ursa Major constellation. And to do the assessment as much as possible in a time of year when it is not - or less cloudy. You then see that the star will slowly manifest itself again in the hole. Then you can say that the Earth has completed an orbit around the sun, and we call that a year. Whether that is 365 days (365 planetary rotations), I leave that to your observation?

Now we can start to structure and shape this phenomenon in time. For this we need an interval. We used to have an hourglass for this, now a watch. We call this equal interval a second.

So, we determine as a human being on Earth that 60 seconds is a minute and 60 minutes is an hour, and 24 hours is a 24-hour period (a day), which is equal to one rotation of the Earth about its own imaginary axis.

So, it's easy if you know how to do it, see figure 73.

So, if you look through the pyramid shaft on a specific day (from the king's chamber) and you see a fixed star from Orion's belt, you have captured a perfect time.

The star disappears from the viewing angle of the shaft and will be seen again a year later in exactly the same place. You have then determined a year in time perception. The day is therefore determined by the star that always remains visible in the shaft for at least one day.

*All you need to know is the day when the stars connect to the shafts.*

Today, 2022, we no longer know this.

The simple example in figure 73 shows how to do it.

### **The Golden Spiral in the Great Pyramid.**

- **The new golden spiral.**

The golden spiral of Fibonacci (based on squares) needs no further explanation, we know it.

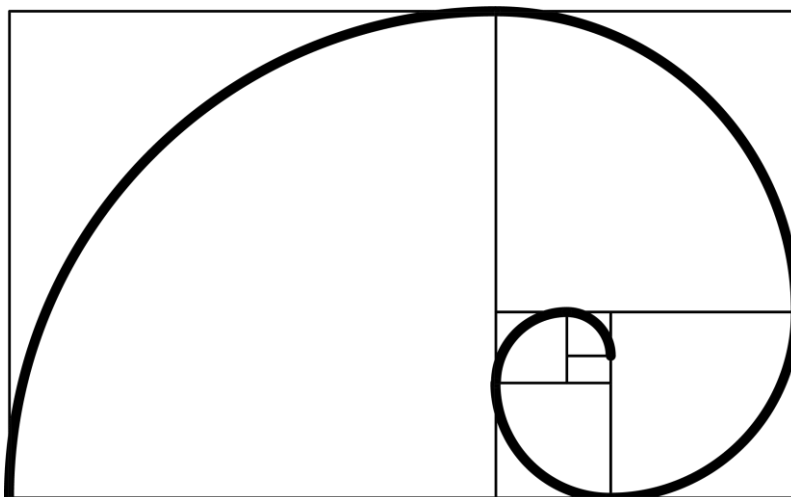

I now show you two other golden spirals based on the pyramid. Then decide for yourself which spiral comes into its own in figure 77.

The Great Pyramid is made up of 4 equilateral triangles and a square base. I now show you my golden spiral, constructed from the equilateral triangle, figure 74.

Draw an equilateral triangle with sides of 12 cm (blue). Divide the corners and determine the center point. Inside this equilateral triangle, draw a smaller equilateral triangle of 6 cm ( $12/2=6$ ) (yellow). Then draw a smaller equilateral triangle of 3 cm ( $6/2=3$ ) green. Draw another 1.5 cm ( $3/2=1.5$ ) equilateral triangle in purple. See figure 74.

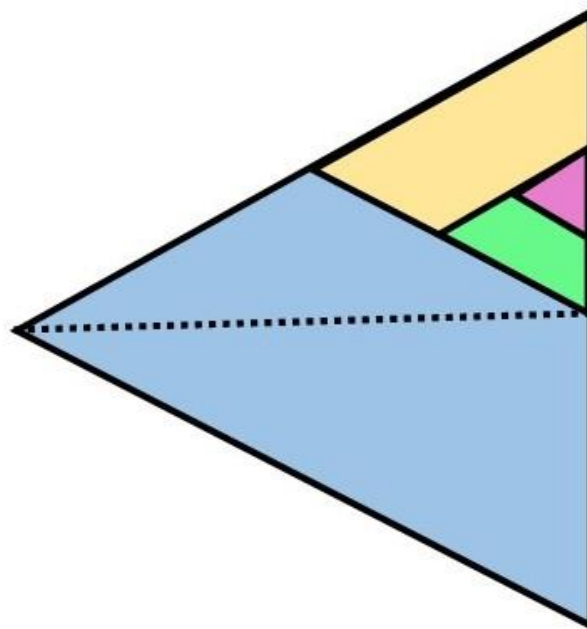

**Figure 74**

If you have done this correctly, you can draw the golden spiral as shown in figures 75 and 76.

Actually you only need a right-angled triangle in the ratio: 1 : 2 :  $\sqrt{3}$ .  
( $30^\circ : 60^\circ : 90^\circ$ )

From the two smallest triangles (purple and green), draw a  $2/3$  circle around their two sides. Then draw a  $1/3$  circle line from the yellow triangle that connects to the bottom corners. Then draw a connecting line from the large triangle to its other point. And you have the golden spiral based on the 12 cm equilateral triangle. Figure 75.

*The figures can be slightly distorted due to manual construction, however if you draw the perfect then you have a perfect golden spiral.*

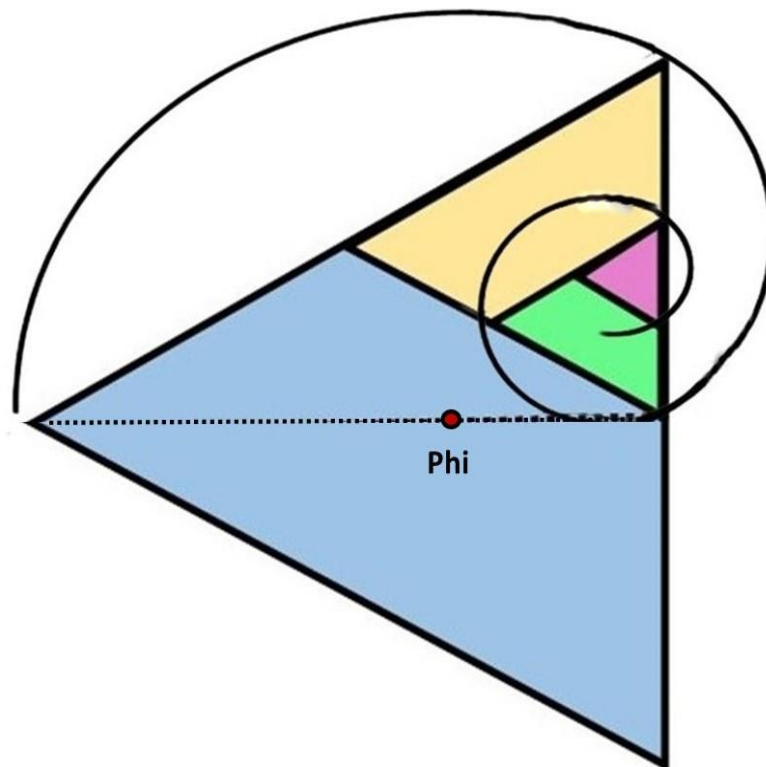

**Figure 75**

If you now look closely at figure 75, you will see that in principle you only need a right-angled triangle, with a small straight side of 6 cm and a hypotenuse of 12 cm. You must then plot the triangle center of the large equilateral triangle on the longest straight side  $\sqrt{3}$ .

How do you do that?

### The number Phi.

How do I get the number Phi (1.61) in the equilateral triangle? The ratio 6:6:6 is again essential. Draw an equilateral triangle with sides of 6 cm. The straight side is then  $\sqrt{3} = 5.196$  cm. Now how do you determine the center point of the triangle, which allows you to draw a circle around it. To do this, you divide the corners through the middle, so that you get two diagonals of 5.196 cm. If you now measure the distance at which the points intersect in the middle, 1.61 (Phi) will appear at the bottom.

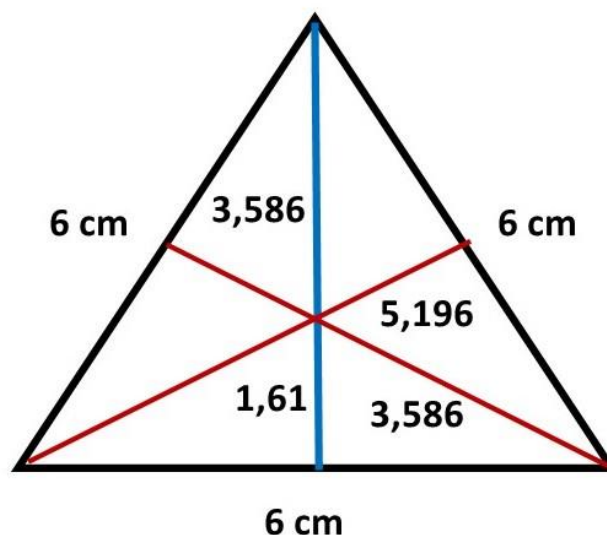

The center point of an equilateral triangle of 12 cm is then twice as large, is  $1.61 \times 2 = 3.22$  cm. You have all equilateral triangles reduce to the ratio 6:6:6.

***Phi = sum of the two hypotenuses minus the sum of two straight sides.  $Phi = (2 \times 6) - (2 \times 5.196) = 12 - 10.39 = 1.61$ .***

***(3.586 + 1.61 : 5.196 - 3.586)***

Now the golden spiral in the right-angled triangle.



Figure 76 shows the right-angled triangle in the ratio 1: 2:  $\sqrt{3}$ . This golden spiral is therefore based on the knowledge of the pyramid and the equilateral triangle.

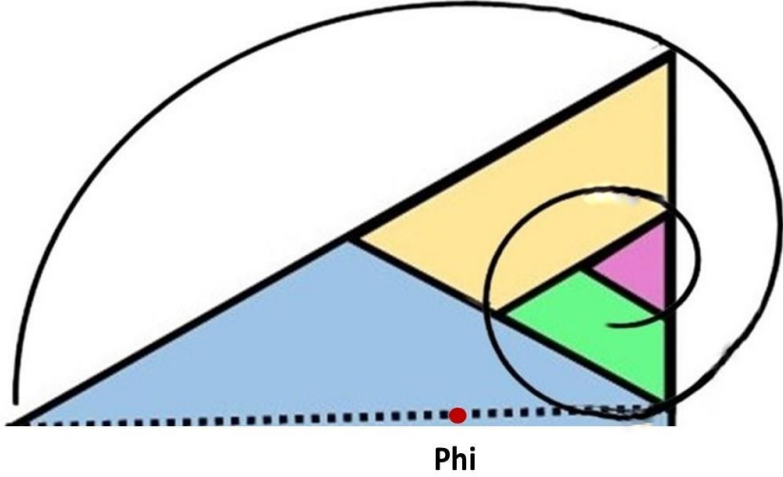

Figure 76

Now let's project the two spirals into the Nautilus projection, as it is depicted so often on the internet, figure 77. The yellow spiral is Fibonacci's spiral (based on squares), the blue spiral is my spiral based on the equilateral triangle.

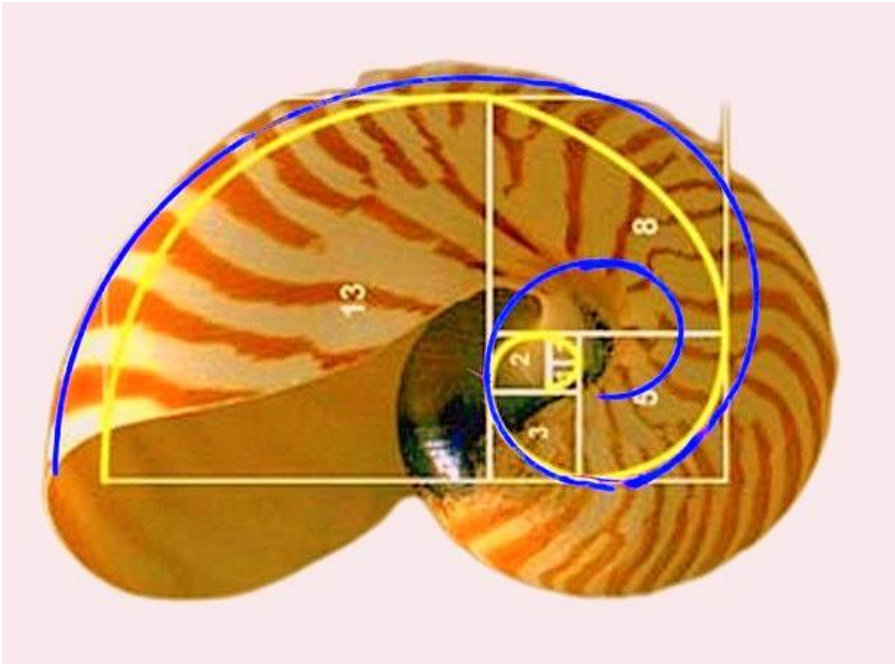
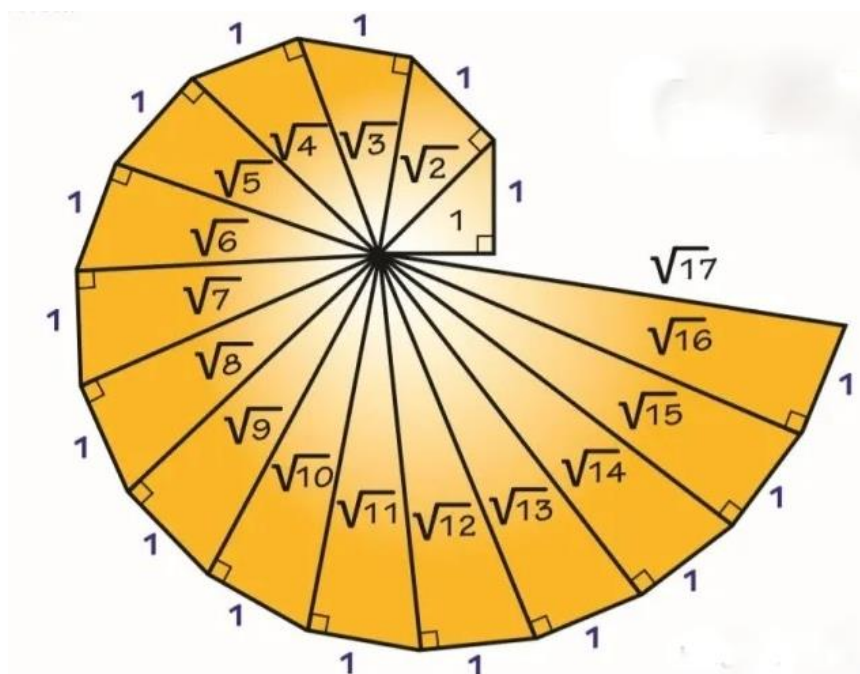

Figure 77

## Golden spiral from the Theodorus spiral.

If you look at the internet, then it is written about this:

*The **Theodore's spiral** is a spiral created by sticking right-angled triangles together. One starts with a right-angled triangle with right-angled sides of length 1. Then a side of length 1 is glued to the hypotenuse at a right angle, thus forming a second right-angled triangle. This process is repeated and thus the spiral of Theodorus is created. The hypotenuses of the right triangles in this spiral form the sequence  $\sqrt{1}, \sqrt{2}, \sqrt{3}, \dots$ . This follows directly from the Pythagorean theorem. The actual spiral is formed by the glued rectangular sides of length 1. None of the hypotenuses in the spiral coincides with a previous hypotenuse. The spiral of Theodorus is named after Theodorus of Cyrene who first constructed the spiral. Theodore of Cyrene lived in the 5th century BC.*



**Theodore's spiral**

What is striking is that the ratio is set at 1. This indicates that people were not known at the time, with the pyramid triangle in the ratio  $\sqrt{1} : \sqrt{2} : \sqrt{3}$ . I have adjusted the spiral to its correct proportion, figure 78.

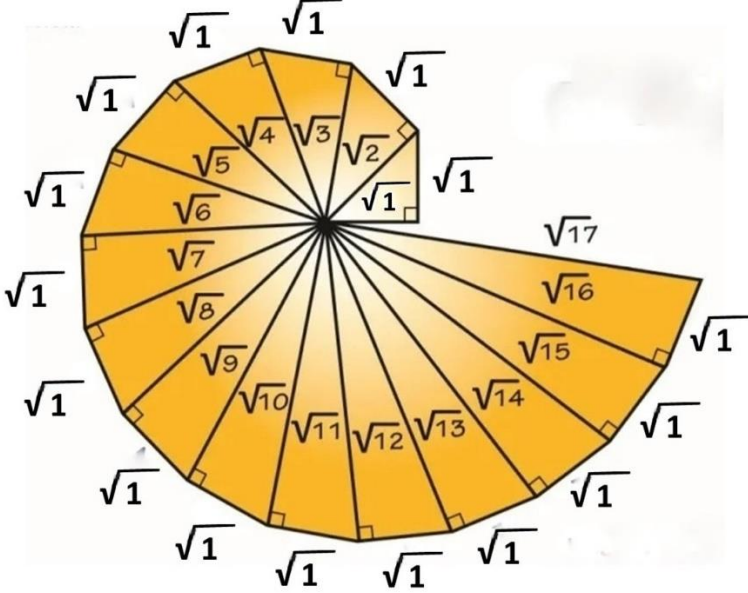
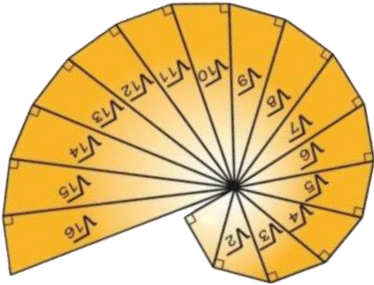

Figure 78

This spiral descends from the Great Pyramid. He is distracted in this. What can you do with it now and why was it designed this way? *It is stated that Theodorus stopped at  $\sqrt{17}$ , presumably because that is the last one not overlapping a previous triangle.* I think people don't understand what Theodorus was saying with this spiral. If you look closely, it is the golden spiral. That's why he stops at  $\sqrt{17}$ .



Now you can ask the question, how do you draw the circle line around this spiral?

I'm going to explain that to you.

***I am now going to provide you with the proof and ask you to draw and test this yourself.***

Draw a triangle in the ratio:  $\sqrt{1} : \sqrt{1} : \sqrt{2}$ .  $\sqrt{1}$  here is 3 cm.  $\sqrt{2}$  is then  $3 \times \sqrt{2} = 4.24$  cm, figure 79. Then connect the following triangle:  $\sqrt{1} : \sqrt{2} : \sqrt{3}$ .  $\sqrt{1}$  is the fixed constant of 3 cm.  $\sqrt{2} = 4.24$  cm and  $\sqrt{3} = 5.19$  cm. Connect the following triangle  $\sqrt{1} : \sqrt{3} : \sqrt{4}$ .  $\sqrt{3} = 5.19$  cm and  $\sqrt{4} = 6$  cm. Continue in this way until you draw the last triangle of the golden spiral:  $\sqrt{1} : \sqrt{9} : \sqrt{10}$ . (3cm : 9cm : 9.48cm).

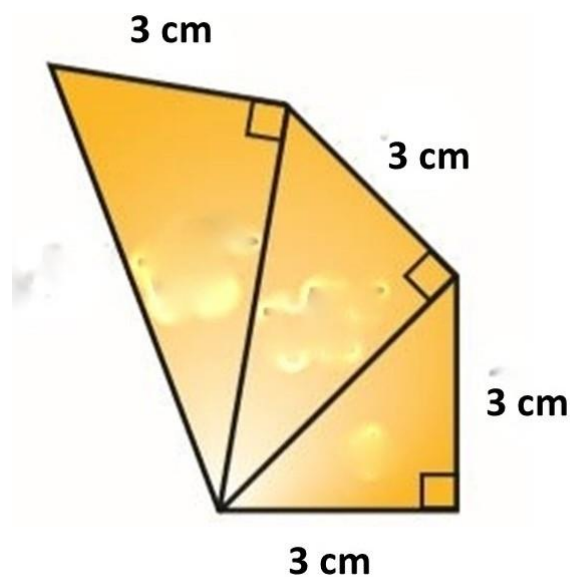

Figure 79

If you did it right, you have drawn 9 triangles.

How do you draw a circle around the triangles in figure 79 so that all triangles fit together perfectly?

Figure 80 shows this.

Please note that the figure 81 shows a distorted image, because it is constructed by hand. However, if you draw it perfectly, you will see how the circle lines connect seamlessly.

Mark off 1.61 cm ( $\phi$ ) on the v3, v4, v9, and v12 line.

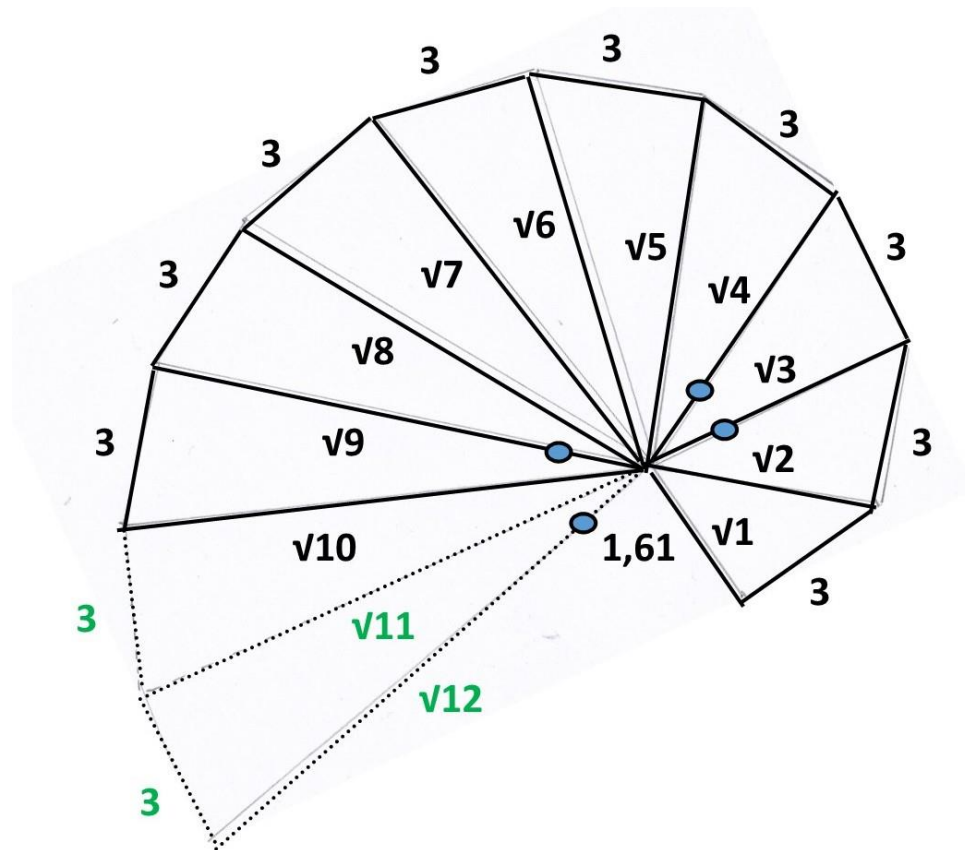

Figure 80

- Putting off 1.61 cm on v12 makes the circle line over v10, v9, v8, v7 and v6.
- Putting off 1.61 cm on v9 makes the circle line over v6, v5, v4 and v3.
- Putting off 1.61 cm on v4 makes the circle line over v3, v2 and v1.
- Putting off 1.61 cm on v3 makes the circle line from v1 to the half ( $R = 1.61$  cm) ( $\phi$ ) circle in the center

To make it complete you need to make two extra triangles that have nothing to do with the golden spiral itself. They are only intended to be able to deposit the number 1.61 (phi) on the v12 line, to draw the circle line over the lines v10, v9, v8, v7 and v6.

Then the connection to the middle, see figure 81.

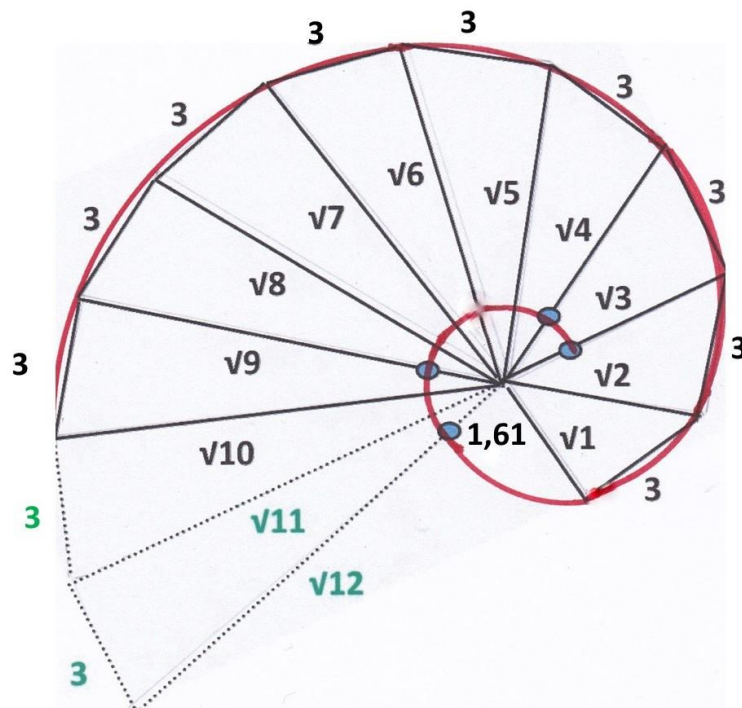

Figure 81

You can draw a circle in the center, with a radius of 1.61 cm. In this way you can also easily determine the take-off points, figure 81. Now plot an extra point on the v3 line. From this point you can make the connection of the v1 line, which connects seamlessly to the circle in the middle.

You then have the second golden spiral that can be traced back from the Egyptian Great Pyramid.

That was the intent of the Theodore spiral, so it stopped at v17.

Much knowledge has been lost over the centuries.



## Chapter 2

### Cosmic Phenomena

This chapter describes some cosmic phenomena that raise the question of whether what we know (2022) take as truth?

I deal with three topics in which this question is tested against what I describe.

**I'll start with the Orion mystery.**

*A **mystery** is an incomprehensible or inexplicable fact. Some inexplicable phenomena were created by nature, while others must have been performed by humans. Many mysteries continue to lead to questions to this day.*

*Most mysteries are difficult to solve because there is too little scientific evidence. However, with human knowledge increasing every day, there are also phenomena that were once inexplicable but are no longer a mystery, such as why people can't fall off the bottom of the earth. This gives hope that many things that are unclear to us today will one day receive a scientifically conclusive explanation.*

*This is on the internet.*

I call the above *my Orion mystery*, because what I first describe cannot be correct, if I test it against the constellation Orion, and in particular against the 3 stars of the belt of Orion.

To understand this, you need to know some things that I am going to explain.

We start with the positioning. Geometrically you represent the Earth as a Sphere, a round planet.



We are now going to describe the properties of the Globe in relation to man, figure 82.

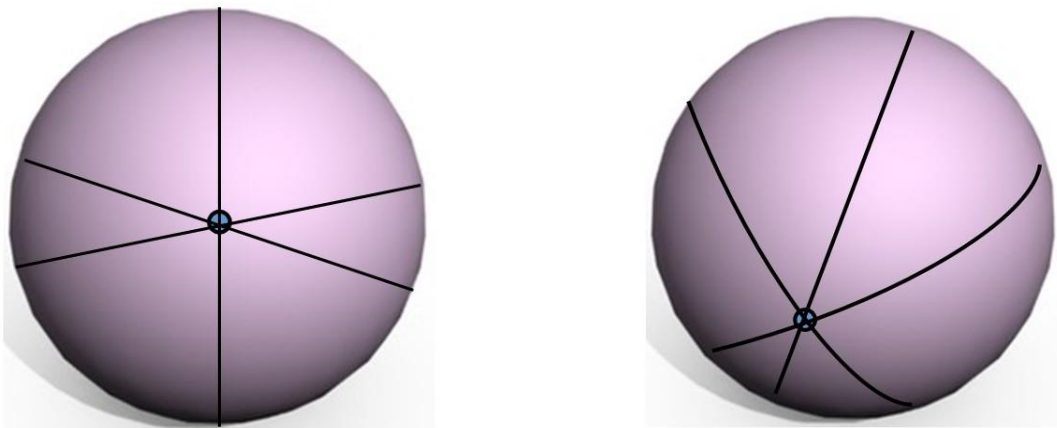

**Figure 82**

Suppose you as a person are the blue dot on the Sphere. You walk in one direction and keep going straight. What do you see then?

***Wherever you walk, you as a human being from your position always walk across the center of the Sphere, (Earth).***

As a human being you cannot walk in a bend (circle), you always walk straight in a line.

Many will not understand this, I explain this.



If you look at figure 83 you will understand. If you walk straight on the left Sphere from bottom to above, you walk across the center of the Sphere. If you now turn right or left, you will walk again from your position across the center of the Sphere, (Earth). You cannot leave the middle as an individual.

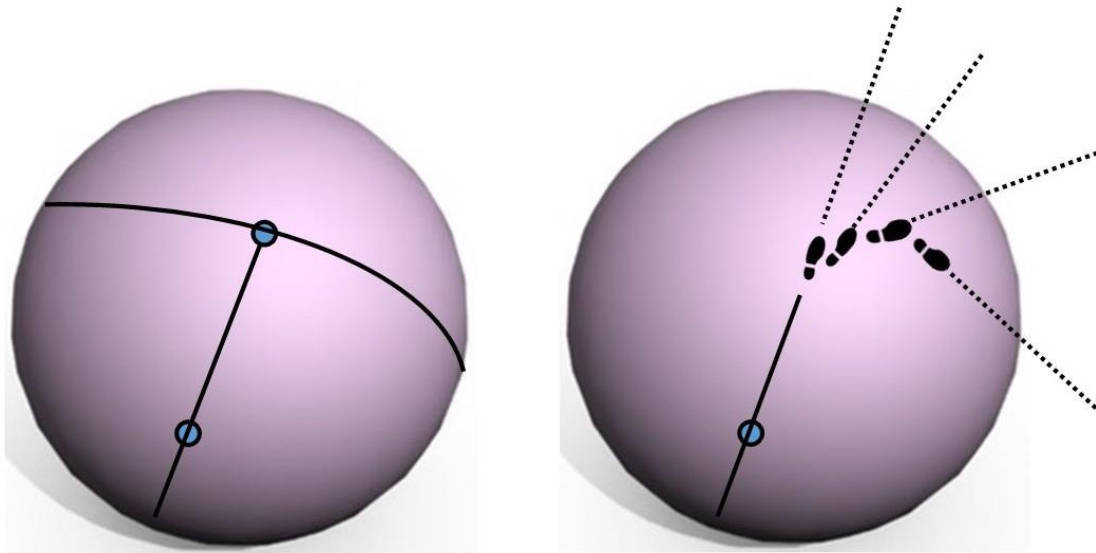

**Figure 83**

Every footprint you set up in one direction and join the other is always a straight line. You cannot walk in a circle (curved line). I refer again to the Theodore spiral in figure 78. In this way you practically walk an imaginary circle in your experience. Step by step in a straight line.

What we also know is that as human beings we are in a perpendicular position (perpendicular equilibrium line in human beings), directed towards the center of the Sphere, (Earth).

So, wherever you stand on the Sphere, (Earth), you are always perpendicular to the center.

What else does this show?

***Figure 84 shows that wherever you stand as an individual on the Sphere (Earth), you are always on the highest point of the Sphere. Because the Sphere is under your feet.***

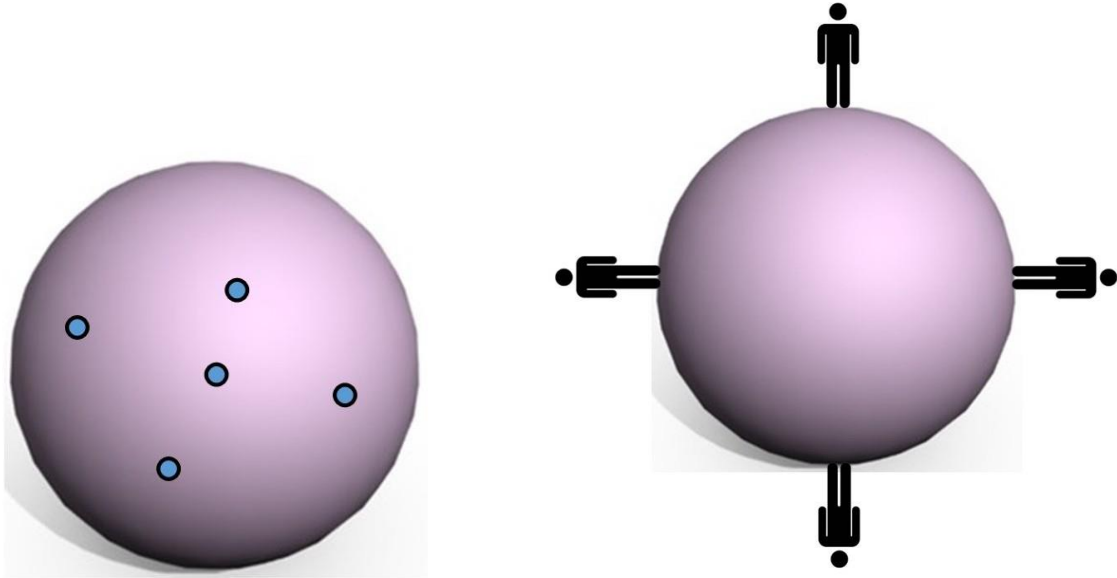

**Figure 84**

Now there will no doubt be some *funny jokers* who say, 'What if you are standing next to a mountain 100 meters high'? Precisely in that case you are right, however if you learn geometry and study the properties of a Sphere compared to the Earth then you know what I am talking about. It can often give you more knowledge than you think.

In summary, you can say that:

***Wherever you walk, you as a human being from your position always walk across the center of the Sphere, (Earth).***

***Wherever you stand as an individual on the Sphere, (Earth), you are always standing on the highest point of the Sphere from your position.***

And that goes for all 7 billion people on this planet.

Isn't this admirable?

How is the Sphere facing the stars now? Figure 85.

Suppose you are standing (perpendicular) at position A and looking at the star. If you now draw an imaginary horizontal line from under your feet, you can roughly determine the (viewing) angle at which this star is from your position.

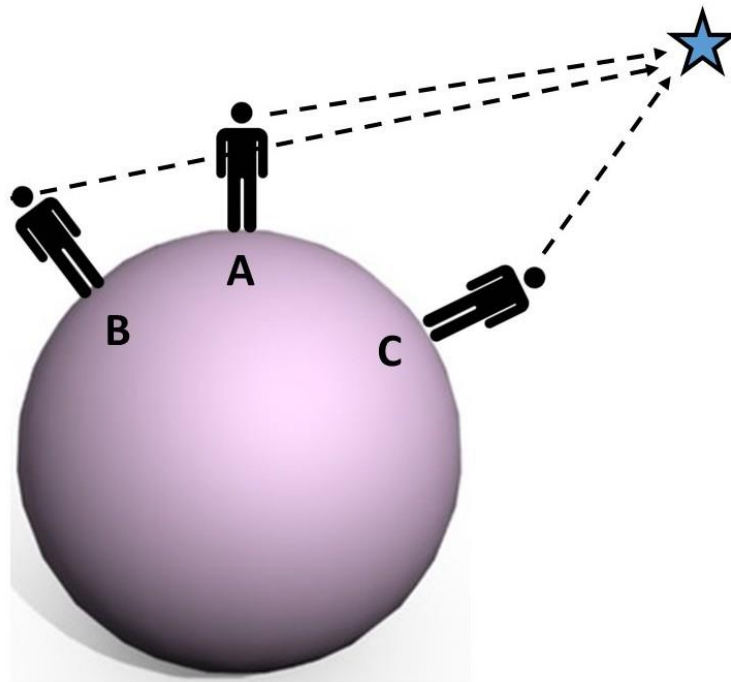

Figure 85

An hour later, the Earth (Sphere) is different. The Earth rotates at a speed of 1600 km per hour and is moving forward at a speed of about 108,000 km per hour. An hour later you are in position B relative to the star if you have remained in the same place during that hour. The viewing angle is now different.

The same goes for position C.

This indicates that there is never a fixed angle from Earth to the stars because everything is in motion. The angle measurements are therefore approximate and the further the star is from the Earth, the better the angle determination matches.

I have already indicated in chapter 1, the Orion pyramid shaft, how the best star determination works (figure 60 and 73).

When you come back to position A in figure 85, you can say that you have again reached the benchmark of your first observation and your possible angle determination.

**Now we go to my Orion mystery.**

I am going to take a closer look at the Earth projection that is prevalent at this time of 2022.

We have stated that Orion is approximately equatorial in the sky, figure 86. If you look at Orion from the North, you will see it in the opposite projection (mirror image) from the South.

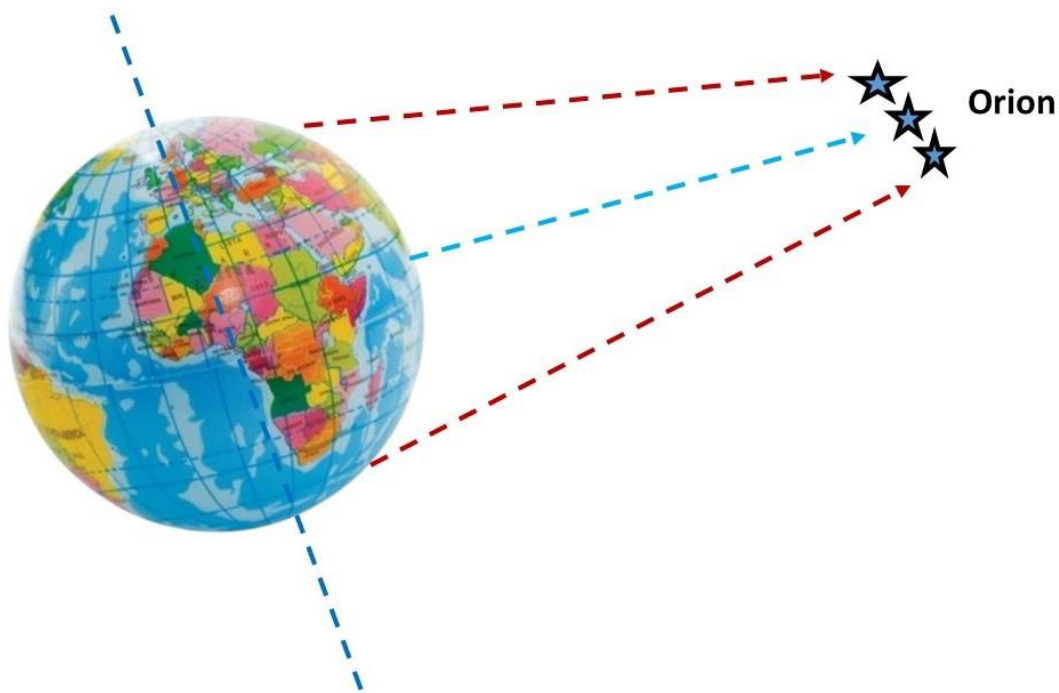
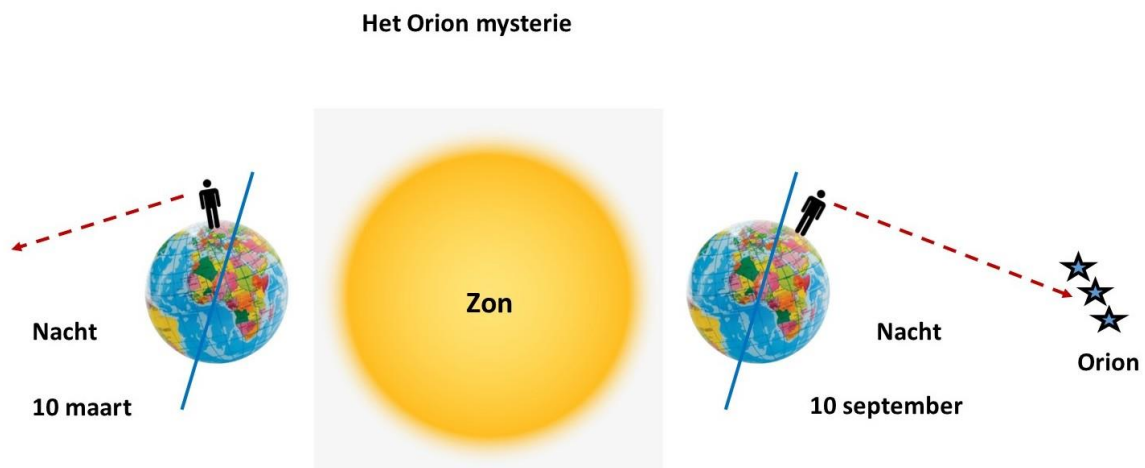

**Figure 86**

Now let's examine all this.

On September 10 I will look at the belt of Orion from the Northern (N ↑) hemisphere (Netherlands) in the night. I see the three stars at a viewing angle of about 60 degrees. Beautiful to observe. We say that the Earth revolves around the Sun in 365 days, 12 months. This is what we have tuned the Earth projections to.

Now for the projection, figure 87.



**Figure 87.**

In this way we project the Earth around the Sun, an imaginary oblique axis in the center that explains the seasons.

On **September 10**, I look into the night (**to the right**), at an angle of 60 degrees, and see Orion's belt (three stars) bright in the sky. Now the question, where is the Earth in relation to the Sun after 6 months, on March 10? Of course, on the other side of the Sun. Now on **March 10** (from the same observation position as in September) I look into the night (**to the left**), figure 87, can I see the stars of Orion?

If so, please explain.

It is therefore not possible in this projection, that should be clear.

***And what is my surprise? On March 10 I see the stars of Orion in the night, at an angle of about 30 degrees still in the sky.***

***How can that be when I look the other way and the stars of Orion are on the other side of the Sun.***

You can now bend over backwards to find an explanation for this, realize that no matter how you twist or turn, the Earth is a pinhead compared to the Sun, figure 88, so you will never be able to see the other side of the sun (in the sunlight).

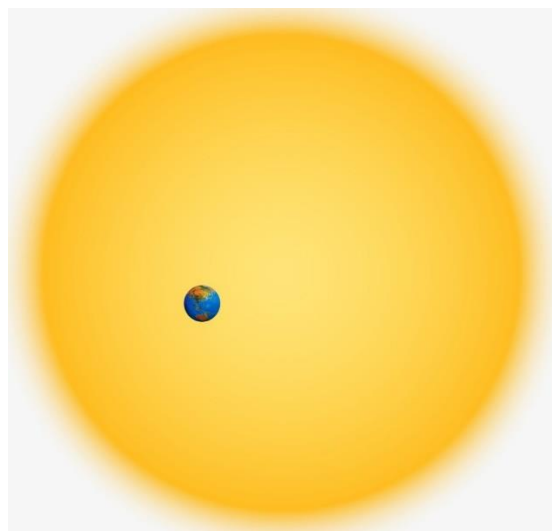

**Figure 88.**

***So, the question:***

***How can I observe the three stars of Orion's belt in September (Netherlands) and in March (Netherlands) when the Earth is on the other side of the Sun and the nighttime view is in the opposite direction?***

This is therefore not possible in the Earth's current projection figure 92. However, you can see him. So, what's wrong now? You can argue that the Earth projection cannot be right. If so, please explain.

A layman would say that then the stars rotate with the Earth. Orion is about 600 light years from our sun. That would mean that the stars would have to revolve around the sun at a speed of about 475 million km per hour (the Earth orbits the sun at a speed of about 108.00 km per hour). So doesn't seem logical to me, especially since Orion isn't within the Sun's attraction. So just explain that.

### **A different view.**

Now I'm going to show you something how it can be done. Know that this can raise many questions. However, you know that the conventional projection you have assumed on Earth cannot be correct (which my Orion mystery, figure 87, shows).

*My projection reflects something else that has been indicated in Earth mythologies for centuries. Something you think you see, but in reality, you don't see.*

I once presented a layman with the Earth projection, figure 87, and asked him what his answer was.

In almost all cases, it was assumed that Orion would have to revolve around the sun, so this is not possible.

I told him that the Earth revolved slightly above the sun, or below the sun depending on which position you look at it.

So not in a straight line around the sun, but slightly (in an oblique spiral line) above or below the sun.

He started laughing and said, what nonsense. If it were, the light would always shine on the Earth from the bottom or top, and the seasons would not match, and the poles would melt.

So, he imagined my projection as figure 89 shows. **A wrong and impossible projection.**

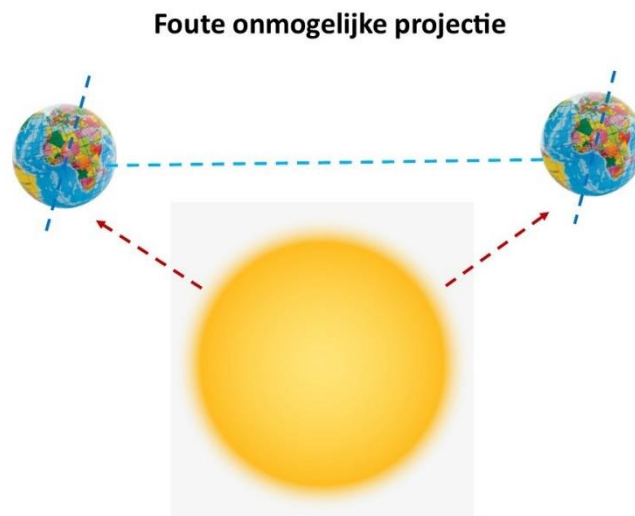

**Figure 89**

How is it that he shaped the projection I gave him in this way in his mind? He was and is, like most of us, conditioned on what is known and believed to be truth. One has no other frames of reference than the one known. The imaginary axis is then again linked in this erroneous impossible projection he imagined to the projection shown in figure 89, which he knows as such.

I told him how my projection looks like and at the same time told him to study this projection before he would judge it.

Knowing that the current projection used on Earth cannot be correct, because the described phenomenon (Orion) in figure 87 cannot be explained.

And this on the basis that man in his equilibrium line is always the perpendicular, figure 84.

Wherever he is.



We are going to place the Earth slightly above the sun, figure 90. The imaginary axis moves with it. The human figures are then in the Northern Hemisphere (the Netherlands). The Earth rotates counterclockwise (in its spiraling attraction) on its imaginary axis. What do you see then?

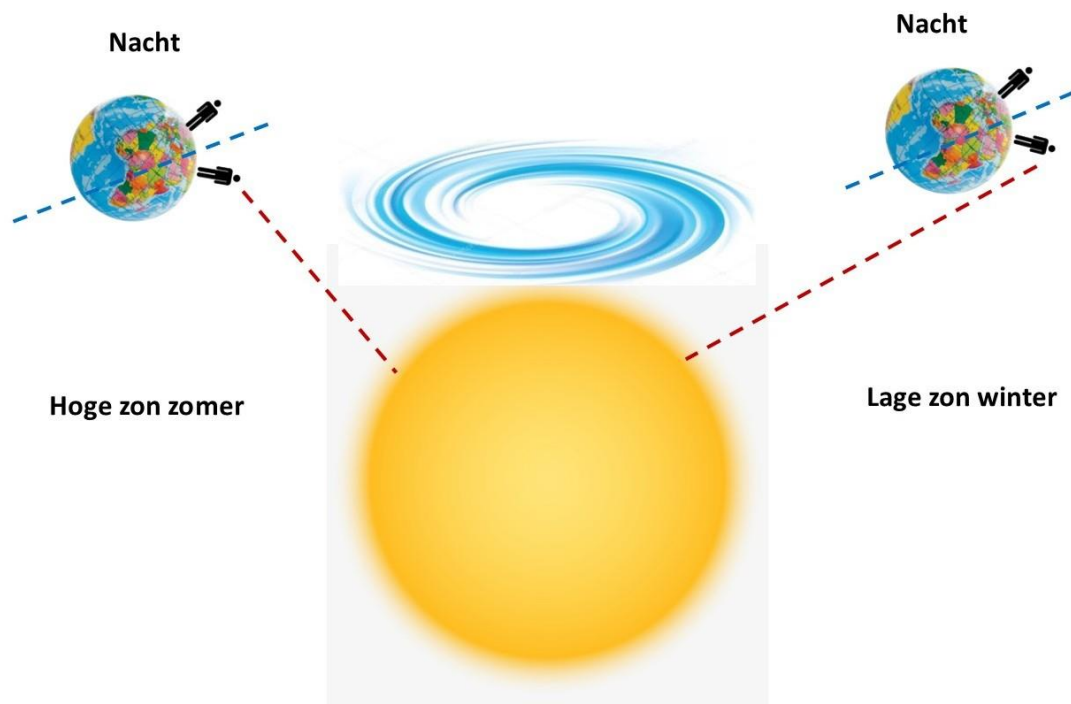

**Figure 90**

You see the seasons return, and you can see all the stars that you see now.

Do not forget that the distances in the Universe have astronomical values that can hardly be studied in detail.

Vision is in many cases distorted with the reality you perceive.

I show you in the next figure 91 how the stars are projected if you take figure 90 as a starting point.

All the stars you observe on Earth form in figure 91

Figure 91 shows that you can see Polaris (Constellation Ursa Major) all year round from the Northern Hemisphere. It shows that you can see Orion on both September 10 and March 10 from the Northern Hemisphere (Netherlands). It shows that if you look from the Southern Hemisphere, you can see Orion in mirror image. And if you look further south, from the Southern Hemisphere, you can see the Southern Cross.

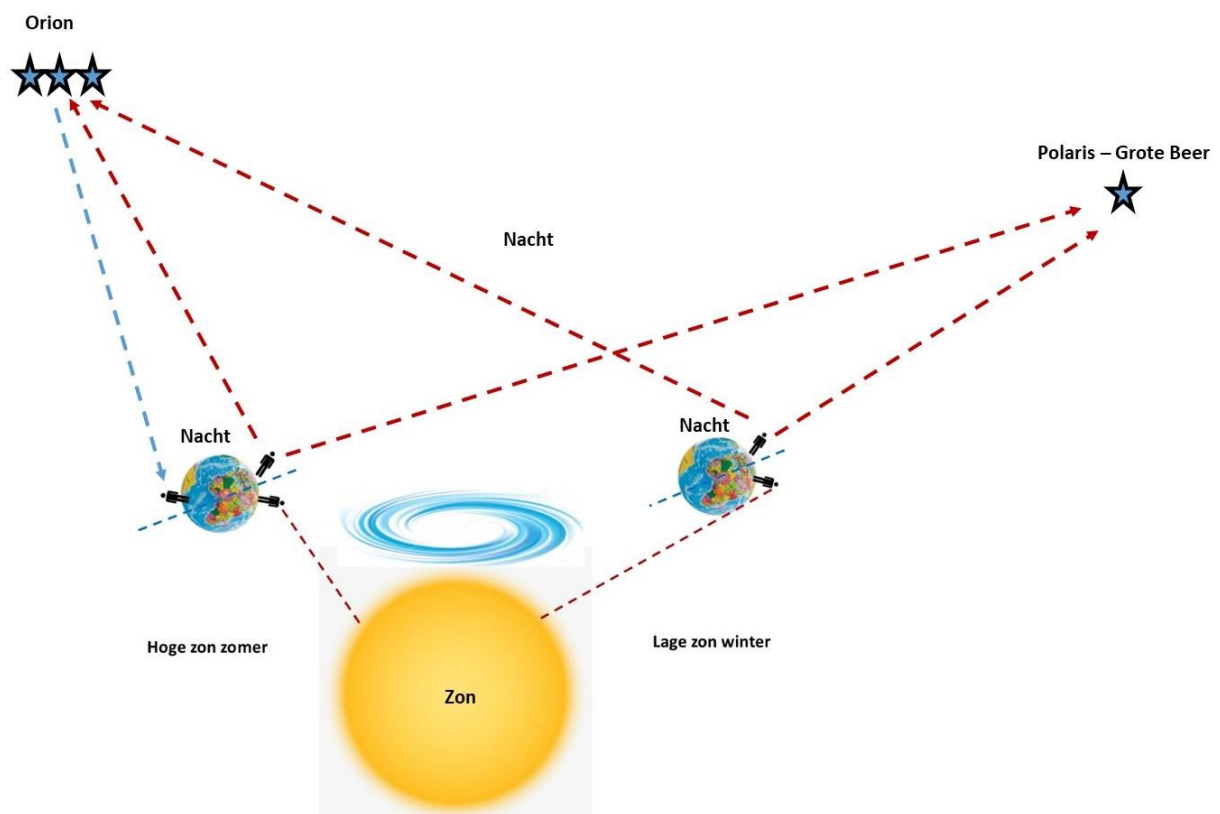

**Figure 91**

Perfection at its best you would say. It is, but you will now be very shocked. If this is true, then we have a 'big problem'.

Because then you see something you haven't seen before.

I explain this using an old Norse mythological story.

It is the story of Odin, the Supreme God.

***Odin is the Supreme God of Norse mythology, the god of wisdom, battle, sorcery, and leadership. Odin sacrificed his eye to the well to obtain all the knowledge and wisdom in the world.***



It's a symbolic story. Why would a god sacrifice one of his eyes to come to Earth? He still sees everything through one eye, so everything from one side. And figure 91 shows that too.

As long as you are on Earth you see everything from one side, and not from both sides. If you were outside the solar system, you would only see reality.

Figure 91 therefore speaks for itself. It is the one side that you perceive with the one eye on Earth.

You don't see what is on the other side of the sun, you see that if you were to go outside the solar system. Then you can see past the sun.

***Or do you have another vision that can explain figure 87 (the Orion mystery)?***

## **Attraction.**

This article describes what attraction is and how it happens naturally. We start with an interesting topic:

- **The definition of Nothing.**

*As a result of this I would like to describe the biblical quotation of John (John's Gospel).*

*In the beginning was the Word, and the Word was with God, and the Word was God. All things were made by the Word, and without it nothing was made that was made.*

So, we have created our own reality.

***What will happen if we don't properly shape the Word as it is intended?***

I think there will be confusion then.

I once asked a learned person in the medical field as we watched the stars in the evenings, 'When you look at that star, what do you see between that star and yourself?'

"Nothing," he said.

So, it depends on how spatially (cosmically) you can think. It indicates the difference between an Earth consciousness and a cosmic consciousness. Please note, I am not judging this at all. I'm just showing you the difference, because every human being on Earth would say, 'Nothing'.

What I personally really see is: darkness and distance.

If you ask man, 'What is between you and the star?' Then in almost all cases the answer will be: 'Nothing'.

Let's start with the Earth during the day. What is between the Earth's surface and the 'heaven' above you. It contains: light, distance, atmosphere (oxygen and nitrogen), clouds, temperature, humidity, pressure, radiation, waves, mass, density, etc.

All this, therefore, man associates with "Nothing" when he looks at the stars.

Now we go into the Universe, what is in it? Nothing ... ? There is darkness, distance, temperature, radiation, waves, mass, density, pressure, etc.

And man associates all of this with 'Nothing'.

Suppose you look at a star and there is nothing between the star and you, would you be able to see the star at all? If there was Nothing between you and me at a distance of 6 feet, could you see me at all?

What do we know now?

We have created a word that we have "torn completely out of its meaning," said symbolically. And that creates confusion. If we don't add the correct meaning to the word then you get complete confusion, also scientifically.

***The scientific definition of the word Nothing is: that it is Not there.***

The ease with which we use the word Nothing and Not in communication also plays a role.

"It doesn't matter what you do." This means: 'Decide for yourself, it's your choice.'

'It does not matter to me'. In this case, too, you leave the choice to the other.

"It will be nothing." In this case, nothing is judging anything.

In communication, the word nothing has many meanings. However, if you use 'nothing' in a scientific context, you should be more careful.

***Because nothing does not exist. Nothing is: that it is Not there.***

***So, you don't know what is inside the Universe.***

- ***Nothing can Exist from Nothing.***
- ***Everything there is Exists.***
- ***Nothing does not exist.***
- ***The Universe Exists.***
- ***And everything that Exists can never Not Exist.***
- ***All that Exists can never be reduced to Nothing.***
- ***It will change shape and will last forever.***
- ***So, there is no Beginning from Nothing, there is and was eternal Existence.***
- ***The Nothing Doesn't Exist.***

**A creation story from ancient Egyptian mythology goes like this.**

***At the beginning of time, when neither earth, heaven, gods, nor men were created, the sun god alone existed in the watery mass of Nun, with which the universe was filled.***

The watery mass with which the universe was filled. This means that the universe was filled with a substance whose specific mass (density) was so great that one could float (float) in it.

Just as you can float on Earth's water, so you could float in the Universe. The ancient Egyptians compared the density of the Universe to the density of water on Earth.

If we now convert the mythological stories into scientific considerations, then you know how the Universe was and is in its structure.

I'll come back to this later.

Let's say that the density of the Universe can be compared to the specific mass (density) of Earth's water.

How then does an attraction arise in a physical way within this Universal mass? I show you this with an example, which each person can test in his own way, figure 92.

### **The stick blender experiment.**

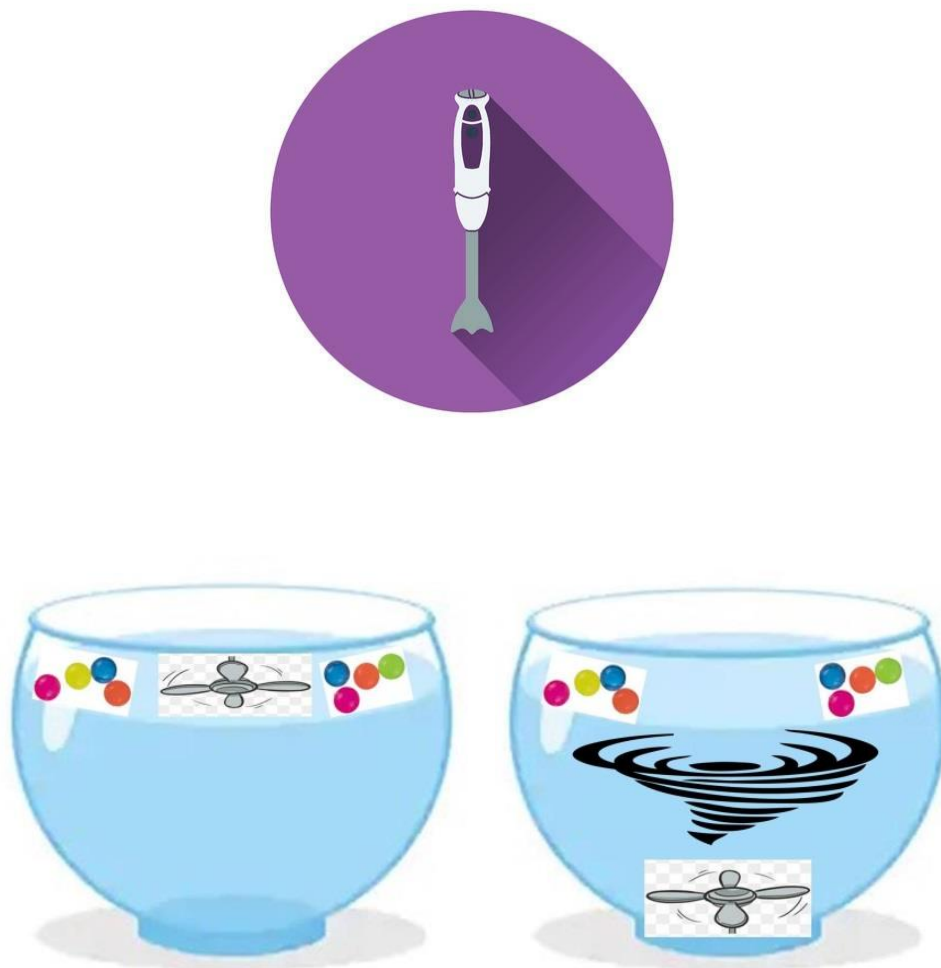
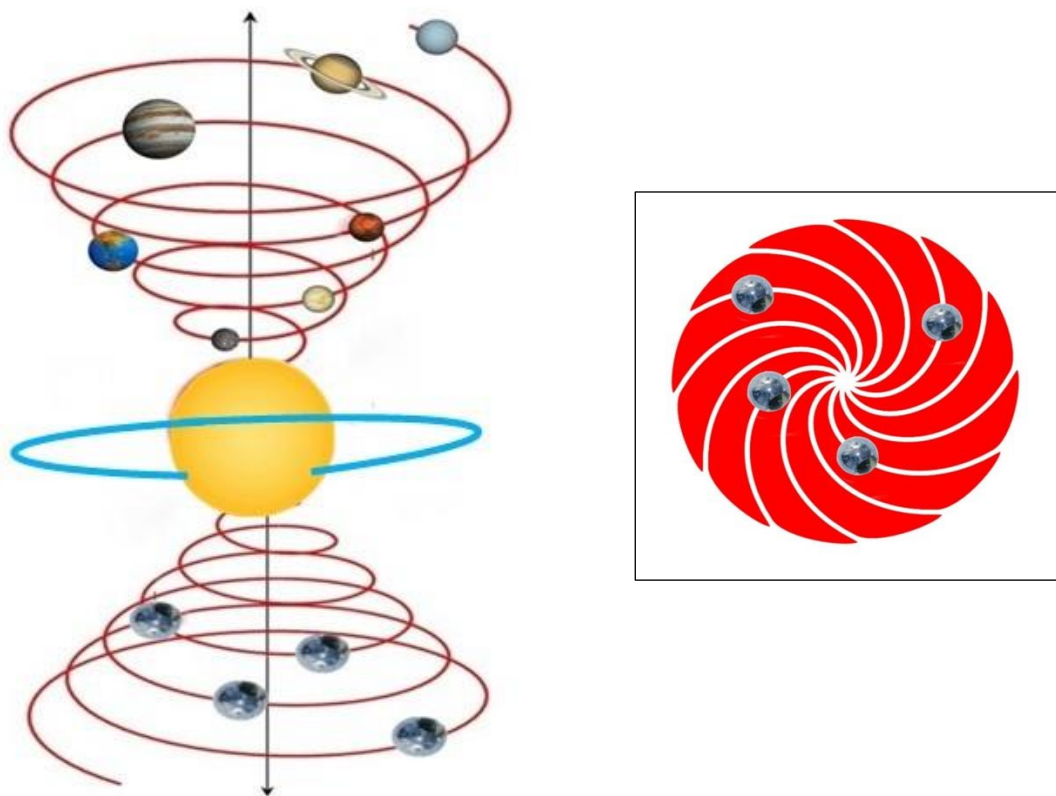

**Figure 92**

Now take two bowls of water. Place gel balls of various weights in this. Some float on the water and some sink deeper into the water and some sink to the bottom, figure 92.

If I now run a stick blender on the surface of the water, you will see that the balls are flying in all directions.

If I put the stick blender deeper into the water, towards the center, you will see that the balls *below* the fast-spinning center and *above* the fast-spinning center are *attracted into the center*. Now if you project this onto a cosmic projection of our solar system, you will see figure 93.



**Figure 93**

The sun, which does not stand still, but revolves very quickly about its center in the 'cosmic water', draws towards itself all the planets in a spiraling homogeneous attraction.



If you project the Universe into a sphere, you will see figure 94. What is happening inside the sphere now? So, there is a homogeneous pressure that sets the mass in motion. The mass will spin and keep spinning. But that is not everything

**Universum**



**Figure 94**

Figure 95 shows how the mass rotates. It rotates in the shape of a pentagram in the sphere and continues to rotate. You see that the pentagram is the symbol of the cosmic rotation. It doesn't stop.

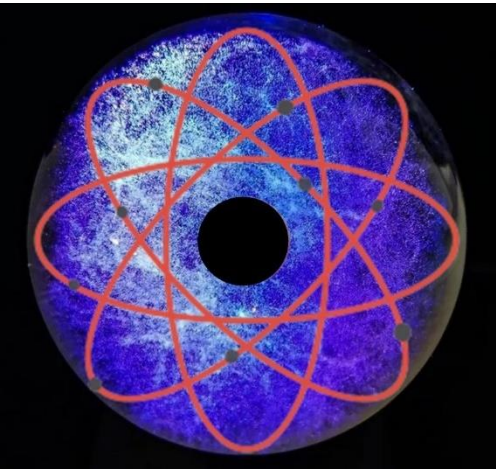

**Figure 95**

## How does the Moon relate to the Earth.

Figure 96 shows that the Moon completes a circle around the Earth in 28 days with respect to the Earth at a speed of 57 km per hour. The Earth has already completed 28 orbits. Both travel through space at a speed of 108.00 km per hour, around the sun.

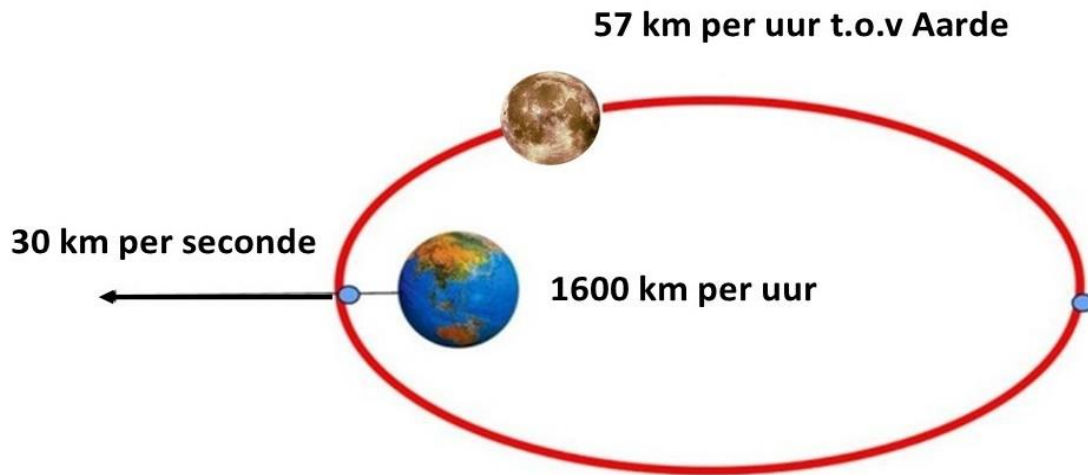

Figure 96

Why do we only see the Moon from one side? See figure 97.

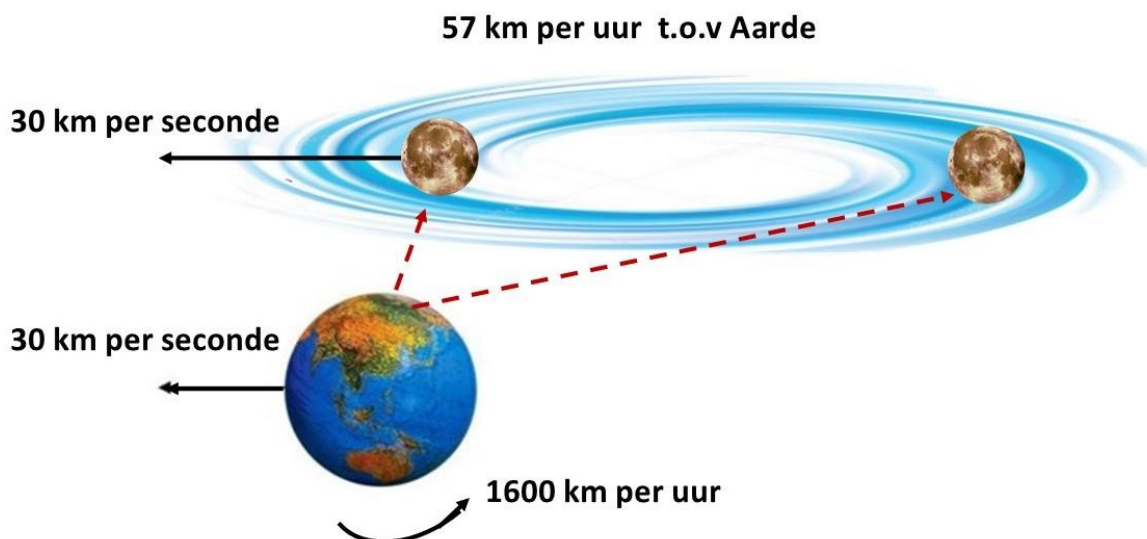
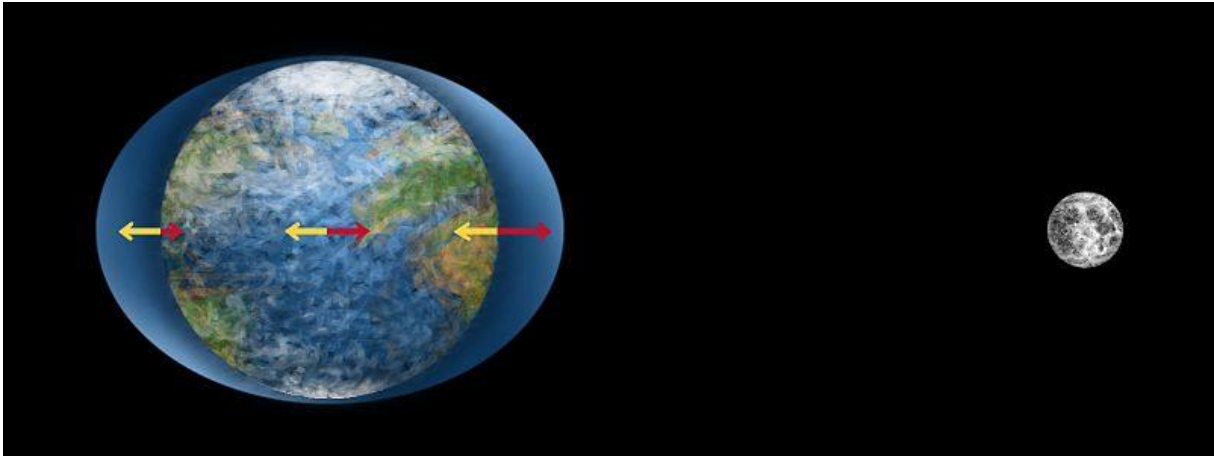

Figure 97

## Ebb and flow



*Figure 98*

I have already described ebb and flow in the *Dutch language publications*. I'll go into this in more detail now. Figure 98 shows the projection how we project it onto Earth. The Moon attracts the water.

All this is based on Newton's law of gravitation. The law of gravitation states that two-point masses attract each other with a force.

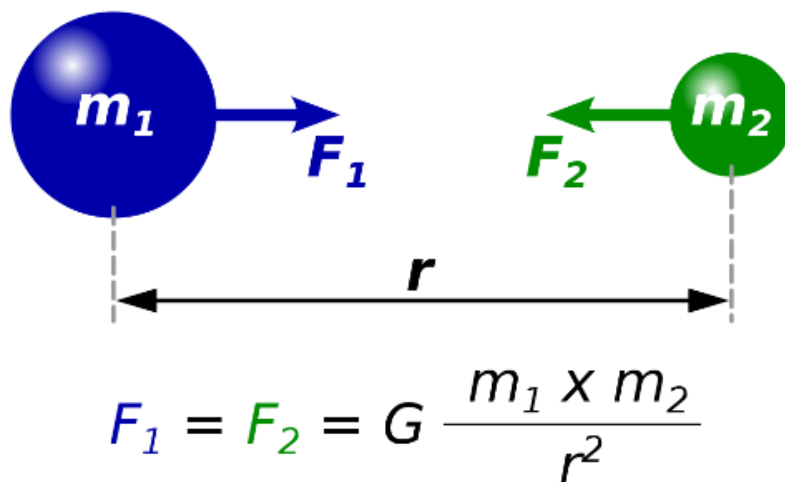

Each point mass affects the other point mass. Newton says  $F_1 = F_2$ . Both point masses act in opposite directions. Now let's examine this.

Let's take an example: F1 with a mass of 10 kg attracts F2, which has a mass of 4 kg.

The question now is, is F1 pulling (attract) F2 and F2 pulling (attract) F1? Does F2 pull (attract) F1 with a force of 4 kg?

I am going to examine this and let the reader of this booklet draw the conclusions that underlie this.

*It should also be clear in this booklet that I myself pretend Aristotelian gravity over Newton's.*

*Aristotle believed that objects fall at a rate proportional to their weight. In other words, if you took a wooden object and a metal object of the same size and dropped them both, the heavier metal object would fall at a proportionally faster speed.*

You can come up with theories, and they can help you find the truth. It is important here that whatever theory you come up with, will only be true if you can test it in practice.

At the same time, it is important that as a scientist you should be able to explain the knowledge in easy language in order not to fall into the trap of Einstein's quote: *'if you can't explain it simply, you often don't understand it yourself'*.

I am F1 and a strong person. I can pull on 10 kg. This means that I am able to attract F2, which has a less force (force 4 kg) than me.

According to the law of gravitation, F2 pulls (attract) on me with a force of 4. And that is not possible. What F2 does do, is give me a resistive force of 4. So, I attract as F1 (10) F2 (4) which has a resistance of force 4. That is logical and understandable.

However, a resistance force is not an attraction. So, you can be sure that two subjects influence each other. By natural law, attraction and resistance are opposed to each other. It is not possible to pull on and pull on at the same time. It is illogical. See the pulling rope below.

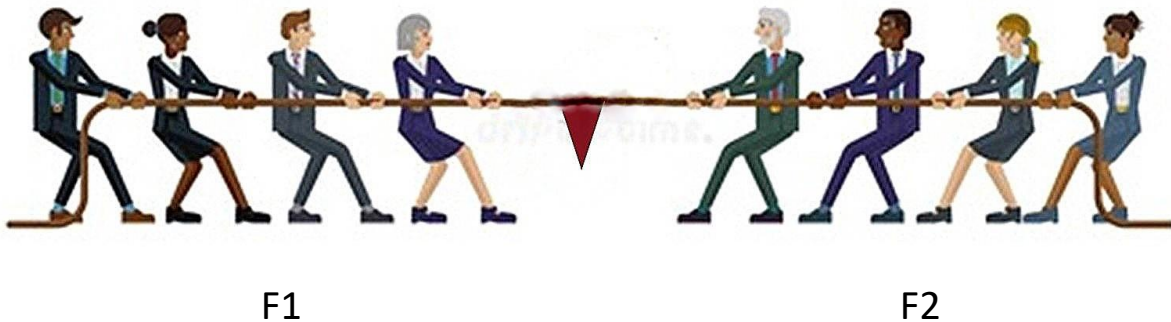

F1 pulls and F2 resists. If F2 pulls, he will first have to bring F1 to a stop (with force 10), in order to then be able to pull him (with force 11) in the other direction.

If F1 pulls with a force 10 then F2 with a force 4 can never attract F1. F1 (force 10) will drag F2 along the ground if necessary because it only offers a resistance of force 4.

*So, the law of gravitation says that the Earth pulls (attract) on the Moon and the Moon simultaneously pulls (attract) on the Earth (?). The Moon (force 4) attracts the water on Earth (force 10) every day. This caused followed this law ebb and flow as shown in figure 98.*

Now, there are many ways to question this law. Note that any theory is well-intentioned, that's fine. A theory from the year 1687 can of course be viewed differently after 350 years.

I'm going to show an example and if you can explain the question in this example to me, I'm immediately inclined to revise my view.

Now suppose it were so. That every day at a distance of 384.00 km, the Moon can attract 2/3 of Earth's liquid mass, figure 99. What would then happen to the Earth's atmosphere, see figure 100?

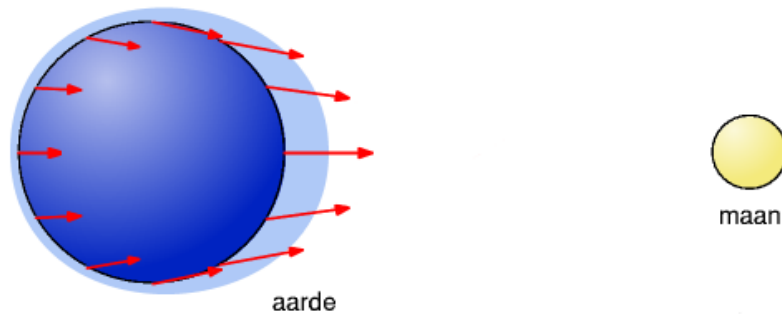

***Ebb and flow under the influence of the Moon's attraction***

***Figure 99***

Air (atmosphere) is much lighter than water, that's for sure. If the Moon can attract the water, what happens to the air (atmosphere)? Then the entire atmosphere would be pulled (attract) daily in one direction (Moon direction), figure 100, that seems inevitable to me, doesn't it?

And that doesn't happen.

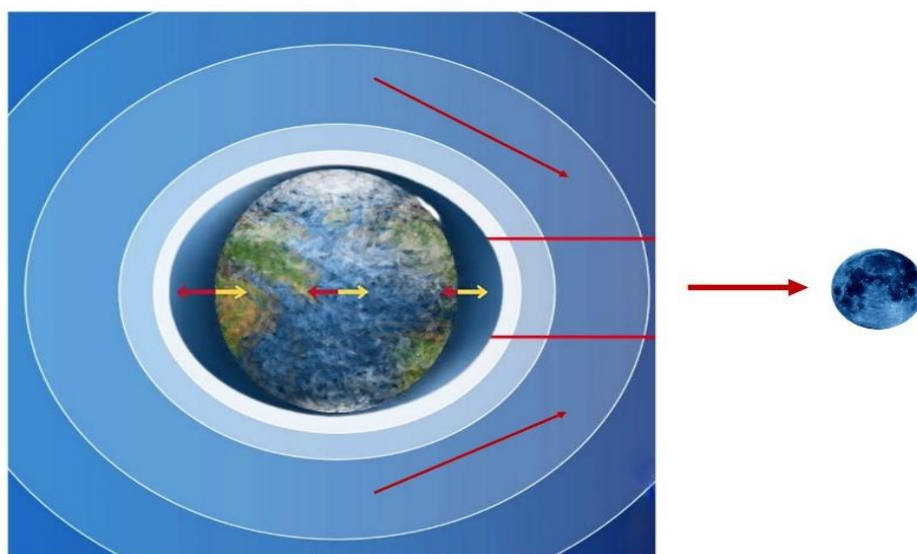

***Figure 100***



Because the (air) atmosphere rotates neatly with the Earth every day. Or would the Moon only attract the water to itself and not the air (atmosphere)? It seems illogical to me, attract something under the atmosphere and not attract the atmosphere itself. How do you do that?

### How then?

Figure 101 provides some simple explanations. When you walk into the wind, you feel how much counter pressure you have to give to be able to walk forward. You are pushed backwards (A). If you turn around now (B) you will feel the wind at your back and the counter pressure has gone and has turned into a yielding pressure. This is the same with ebb and flow. It is a combination of pressure and speed. The pressure and speed (108.00 km per hour) push the water backwards during a forward movement and when the Earth turns halfway, the water falls back again.

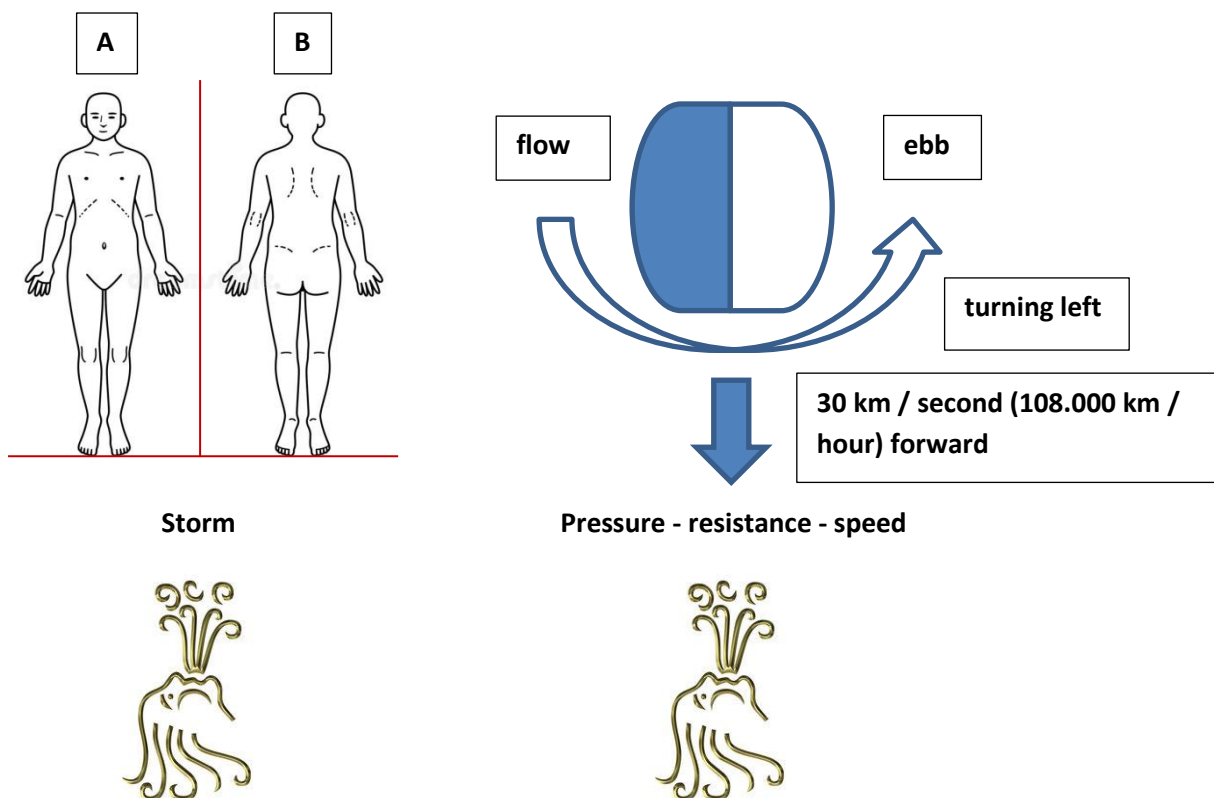

**Figure 101**

## Ebb and flow.

Fill two elongated planters with water and take them under your arm, figure 102. Then walk forward. What do you see? The water laps back. Now turn around as you move forward. Forward and backward forward. You will see for yourself what I indicate here. How ebb and flow arise. A naturally explainable process.

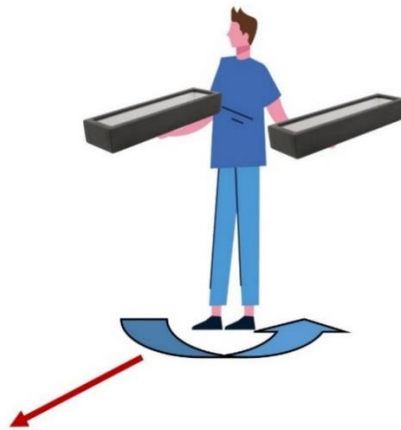

**Figure 102**

If you now project this onto the Earth, figure 103, which is turning, going forward at a speed of 108.00 km per hour, then you know how ebb and flow are created.

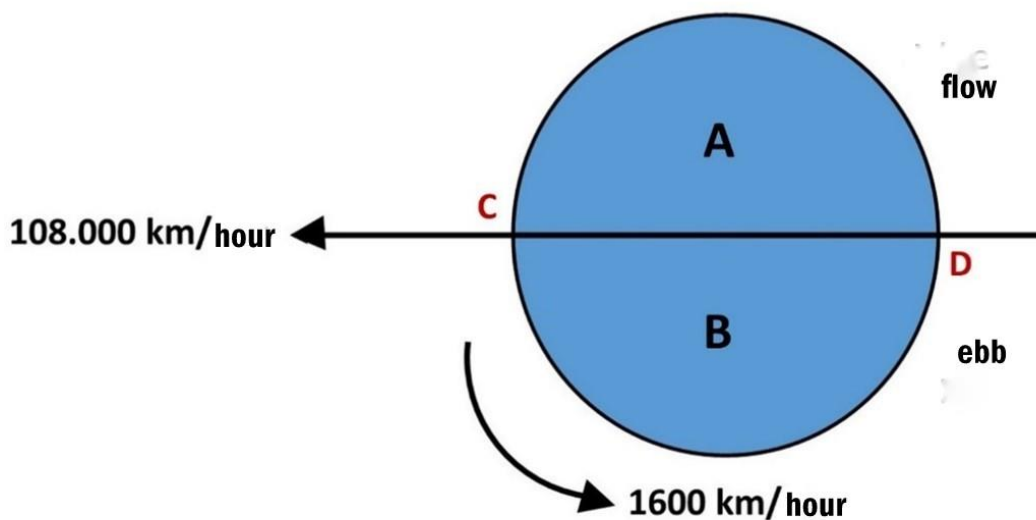
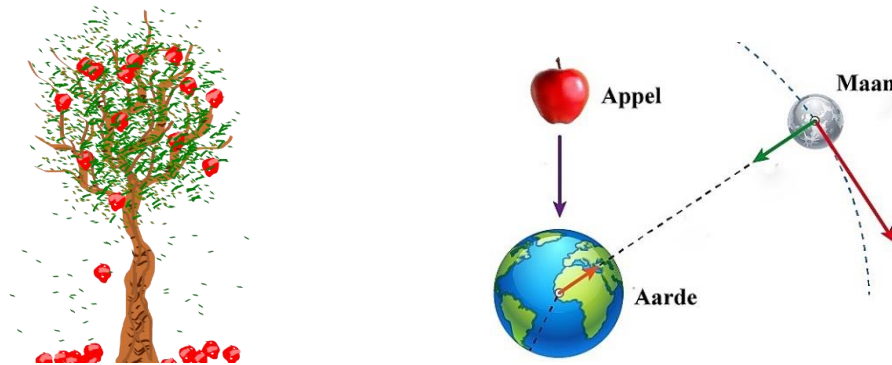

**Figure 103**



## Gravity or free fall

In the late 17th century, Newton described gravity on Earth. Newton saw an apple fall from a tree in his mother's orchard and realized that the same gravity of the Earth reaches so far as to keep the Moon in its orbit.



As a result, Newton broke with the two-thousand-year-old idea of Aristotle (347 BC) that different laws of nature apply on Earth (for an apple, for example) and in heaven (for a celestial body like the Moon). Was Aristotle right or Newton?

Ancient Egyptian creation mythology agrees with Aristotle.

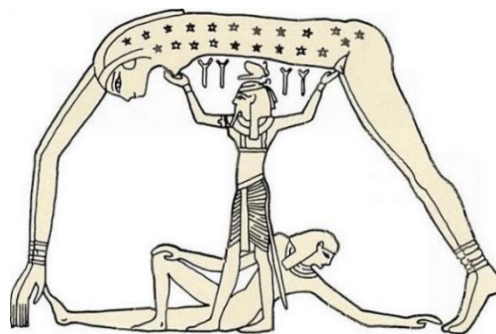

***Shu lifted Nut up***

In this chapter I am going to describe the Egyptian mythology on which Aristotle had built his vision, into a modern scientific vision. *The text in italics is from Egyptian mythology.*

The ancient Egyptian creation mythology goes like this:

*At the beginning of time, when neither earth, heaven, gods, nor men were created, the sun alone existed in the 'watery mass' of the universe, with which the universe was filled.*

The 'watery mass' with which the universe was filled. This means that the universe is filled with an 'invisible dark' substance whose specific mass (density) is so great that one can float in it. Just as you can float on Earth's water, so you can float in the universe. The first Egyptians compared the density of the universe with the density of the water on Earth. The sun was enveloped in the 'cosmic water'. When the sun exploded, it spewed the magma into the 'heavenly waters'. See figure 104 and 105.

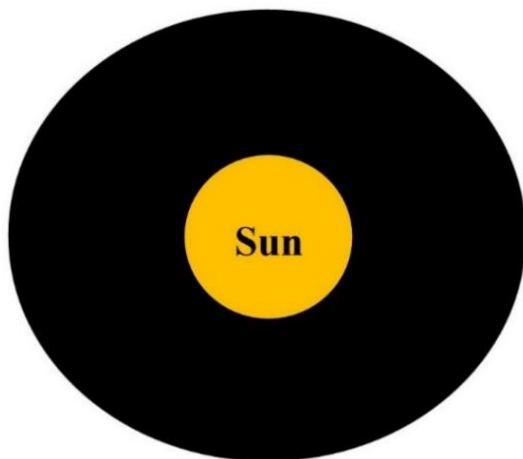

**Figure 104**

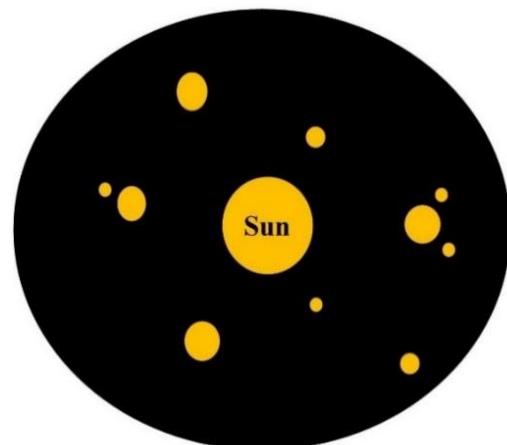

**Figure 105**

The spewed magma now floated around the sun in a cosmic attraction caused by the motion of the 'celestial mass' around a rotating object (sun - planet). Then the magma started to form and depending on its mass took its position within the cosmic attraction of the sun.

The moment a homogeneous state arose within the cosmic attraction field, the magma became fertile.

## How does this work?

One of the magma parts was the Earth.

How did the Earth become fertile?

This has everything to do with the cooling process that I am about to describe. Figures 106, 107 and 108 speak for themselves.

Once the magma has formed and is a hot mass (figure 106), where does it begin to cool? On the outside.

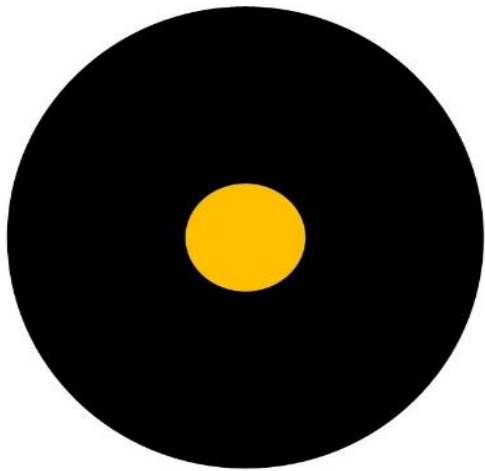

*Figure 106*



*Figure 107*

You can say that a crust (earth) forms over the hot mass. A crust that gets thicker as the cooling process continues, figure 107. So, what happens on the inside?

The magma that is going to be trapped by the outside is going to get warmer. The temperature will rise because the heat has nowhere to go. It's like a human. If your temperature inside starts to rise, we call it a fever and what happens then? You will sweat and the higher the temperature, the more you will sweat. So does the cooling Earth. He starts to sweat and water (the sweat of the Earth) forms.

If you compare this with the fever of man, you can observe the following. Man, sweats and what happens when he goes outside? If he sweats in the summer, you could catch the sweat in a bowl. Then put the bowl with liquid sweat in the sun (temperature distance between sun and earth) and you will see that the sweat remains liquid. Suppose you go outside with a fever in the winter when it freezes, you will quickly observe that the human being freezes and dies.

Returning to the cooling magma thus indicates that the sweat of the Earth (water) forms on its cooling.

The Earth's skin is getting thicker and thicker, and the temperature is getting higher. This sometimes results in an eruption. Symbolically, you can say that the Earth's magma is looking for a way out to the top (volcano) due to the pressure, to then convert the cooling magma (lava) back into fertile land.

During the cooling of the Earth, not only sweat (water) is deposited on the Earth, but the magma also gives off radiation. Radiation that was stronger in the beginning than after the (homogeneous) cooling.

*Shu (the Egyptian god of the atmosphere) was born. How come Shu - atmosphere, Nut (heaven) - lifted - to heaven (Nun - universe)?*

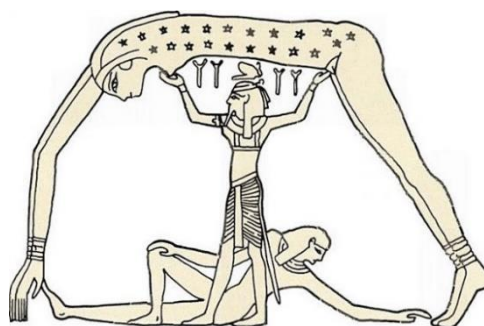

***Shu lifted Nut up***

It's like a child being born. Every child that is born must develop and grow in order to eventually become an adult human being.

The atmosphere also had to develop and how did he do this?

*Sju (personification of the sky) got a girlfriend Tefnet (the embodiment of the moist element of water) and together they formed a connection.*

Now the density of the universe *hugged* Earth's magma tightly and gave the magma little room to breathe. The atmosphere that was born felt the pressure of the universe all around it. The atmosphere felt trapped and erupted. He began to resist the downward pressure of the universe. It became a difficult process, but the atmosphere became so strong that it was able to set the '*celestial mass*' in motion. The atmosphere could build up enormous pressures as time went on that the '*celestial masses*' ultimately could not withstand. He pushed the '*heavenly mass*' from him, into the height. The Earth was no longer suffocated. He now had room to breathe. Now the atmosphere could begin to come alive. The tremendously high pressure of the atmosphere kept the '*heavenly waters*' at distance. He pushed it more than 10 kilometers into the height.

You may wonder how it is possible to move the density of the universe? If the pressure is great enough, you can move anything that cannot withstand the pressure.

Look at the recent explosions on Earth in 2020. A large strong metal silo is pressurized on the inside by a gas that is inside. The pressure of the volatile gas gets bigger and bigger and eventually the heavy metal silo bursts. So, it is clear that pressure has nothing to do with the specific mass of a product. Gas and air are lighter than metal.

The atmosphere does not explode because the '*heavenly mass*' moves. So, there is a homogeneous high earth pressure (with a low specific mass) and a homogeneous universal low pressure (with a higher specific mass).

Figures 106 and 107 show what the beginning was like.

Figure 106 is the Earth's magma enclosed by the mass of the universe (*the water of the universe as the early Egyptians called it, because they couldn't explain it any other way*). A universal mass with a density (specific mass) of let us say factor 10.

Figure 107 shows the cooling process. This starts on the outside (grey color) after which the atmosphere (blue color) starts to form, and the earth's pressure becomes higher, and the universal movable mass (black color) pushes upwards.

*The first Egyptians called the earth Geb and the heaven Nut.*

It may all seem quite logical when you read this. If this is the case then you could also ask yourself, whether everything is as we assume so far?

The title of this chapter is about gravity or free fall. It is about the vision of Newton (1643) and Aristotle (347 BC) that different laws of nature apply on Earth (for an apple, for example) and in heaven (for a celestial body like the Moon).

What can you learn from ancient Egyptian creation mythology?

*Shu (atmosphere) has thus depressed Nun (universal mass) into height.*

What does this mean?

Let us set the density (specific mass) of Nun (the black cosmic mass that fills up the entire universal space) at a factor 10. And suppose that you as a human being can float in this density. Because that is the case.

What then happens when you end up in Shu (atmosphere), which has a specific mass of factor 1?

You fall down like a brick (figure 108), because air has a much lower density (specific mass) than the cosmic mass. A comparable cubic meter of water is heavier than a cubic meter of air. So, if you end up in the atmosphere with a density of factor 1 from the density of the universe by a factor of 10, then it is logical that you fall down in a free fall (see figure 108). And the heavier you are, the faster you fall.

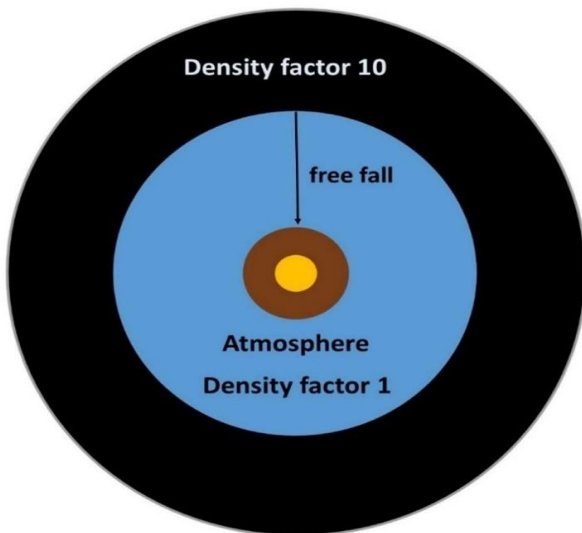

*Figure 108*

### **What is free fall?**

What is falling and how do you fall? You see the reason why you fall. Your own weight (specific mass) is heavier than air. That's why you fall. You always fall to the lowest point. To the deepest fall point.

The point where you can't fall any further. If you project this hypothetically as shown in figure 109, you can see how it works. It should be noted that it really cannot happen. See it as an example of further explanation. Because according to the laws of nature no atmosphere can arise in the spatial mass (by a factor of 10) without the presence of a subject (cooling magma - planet) which creates this atmosphere.

So, suppose that the dark (cosmic) mass in space (figure 109) has a density of a factor of 10 and the white mass is air under enormous pressure with a density of a factor of 1.

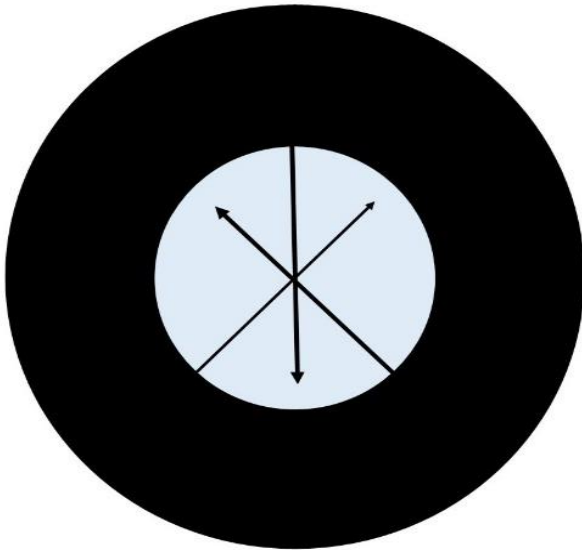

**Figure 109**

It doesn't matter where you enter the atmosphere. You would always fall straight to the deepest point in a free fall. You would then fall back into dark outer space again.

As I have already indicated, this is not possible by natural law, which is why this is a hypothetical example.

Now there is a planet Earth in the middle (figure 108).

Your free fall is therefore interrupted. The Earth will keep you from falling further. You fall to Earth. You can't fall any further. So, you always fall to the deepest fall point. And that is the center of the Earth. The plumb bob confirms this fall point. You can't fall any deeper.

Suppose you have fallen and lie on the edge of a deeper ravine. If you now roll over the edge, you will fall deeper. You always fall straight down to the deepest fall point. You don't fall into a corner.



You see that raindrop heavier than air fall to Earth and connect to their deepest point of fall. They cannot fall any further (deeper). Anything heavier than air (if in this air) will go into free fall and crash to Earth.

In conclusion, you could say that all this has nothing to do with attraction. And as Aristotle pointed out, all objects heavier than air fall to their lowest point of fall and are stopped by the Earth in their free fall.

You could also say that free fall is an Earthly law of nature.

The Moon is not in *Shu* (atmosphere), but in *Nun* (the symbolic 'watery' universal mass of the Universe).

Different laws of nature apply here. Would Aristotle be right after all?

An example of the pressure difference between atmosphere and universal mass can be observed with a rocket that we will launch into space in 2022. The transition barrier between the pressure of universal mass (low pressure) and the pressure of atmosphere (high pressure) shows that if we launch a rocket into space in 2022, it can easily go from a high pressure to a low pressure.

However, the other way around, you see that when it comes back, it has to go from a low pressure to - and through - a high pressure. This creates an enormous friction that makes the flames around the capsule visible when returning to Earth.

Until he goes into free fall.

You can also conclude that any cooled magma has an atmosphere, no matter how small it is, like the Moon. The atmospheric radiation (without the moist element of water) has connected itself with the universal dark mass and depending on its cooling raises the height slightly.

*This chapter was written in response to Aristotle's vision. A view that is supported by Egyptian creation mythology.*

*Aristotle believed that objects fall at a rate proportional to their weight. In other words, if you took a wooden object and a metal object of the same size and dropped them both, the heavier metal object would fall at a proportionally faster speed.*

### **The geometric value of the numbers 1, 2 and 3.**

We sometimes say that you can look at everything from both sides. That everything has two sides, as above so below, as left so right, white and black, etc.

I'm going to show you that this is geometrically impossible. And because it is geometrically not possible, it is also not possible in practice.

The lines prove it.

You must assume that everything that exists has entered into a connection with other elements in order to exist at all.

The first line (1) in figure 110 is a self-contained line that has no further geometric significance based on existence.

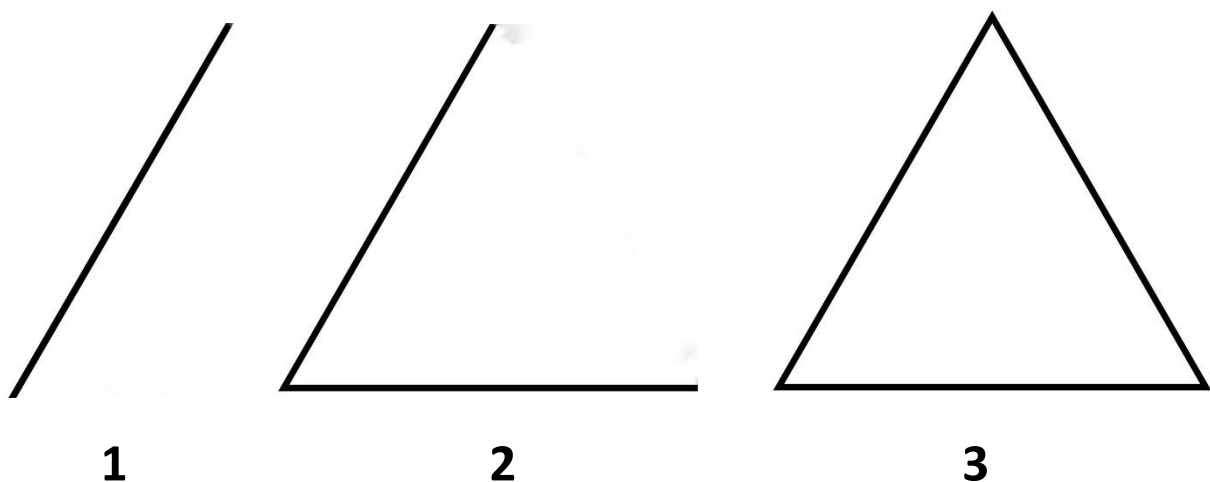

**Figure 110**

This also applies to the two (2) lines. As long as there is no content (3), it does not exist. This means that everything that consists of at least 3 elements (properties) must exist in order to exist.

You can now say that a line does have geometric meaning. It can display the distance between two objects. That's right, what did you do? You have linked the objects (2) to the line (1), so make a connection of three (3).

1 is not content, it is 1 element of an existence. 2 is another element, but still doesn't make existence. The existence form is formed by the connection of three (3) elements. In that case, there is practically content.



If you look at the stone, you will see the trinity (trinity-base connection) of the stone. Form, content, and mass.

- Without form there is no content and mass.
- Without content there is no form and mass.
- Without mass there is no form and content.

You can now add multiple numbers from the basic compound (trinity) 1,2,3, 4,5,6 etc. They then provide more information about the components mass, form, and content.

The trinity mass, form, and content is the basic connection of everything that exists and is present within the Universe. This also applies to physical processes.

Three elements that connect with each other create something.

Let's take the fire triangle as an example. This fire triangle indicates the three elements.

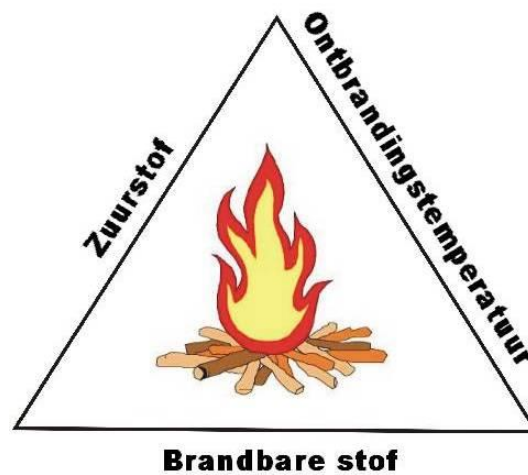

Combustible substance, oxygen, and ignition temperature. If an element disappears or is not there, there can be no fire.

Another example is the wind. What is the trinity of wind. These are air, high pressure, and low pressure.

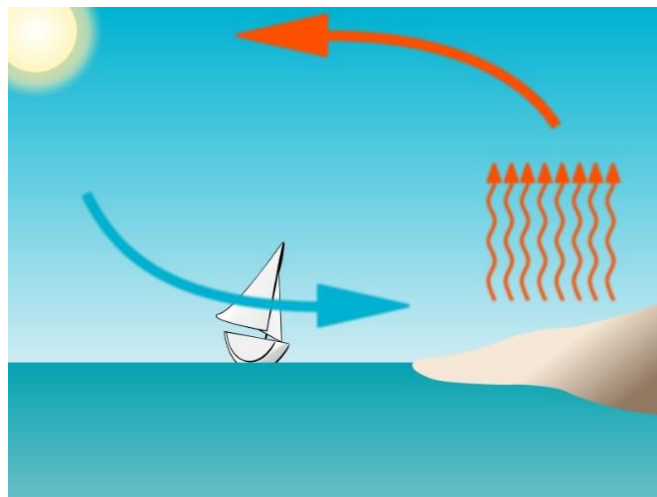

***Air, high pressure, and low pressure.***

So, everything has its trinity. Shown in the geometric equation of the triangle. The smallest (substantive) existence.

If you now bring these properties to man, you will see that man consists of a form, a content, and a mass. And every person is different in form, content, and mass.

Now this all seems logical and understandable. Do you realize that if you say there are two sides to a story, or if you talk about two opposites, or if you have to look at something from both sides, you are not taking the connection (3) into account in your decisions, knowledge or whatever? then?

***Let's determine the trinity of the Universe?***

- ***So that is form, content, and mass.***

Everything within the Universe belongs to the content. All content and form make the mass. As human beings we are part of the contents of the Universe and all contents make up the masses.

Now ask yourself? Suppose your Heart and your Liver had eyes. Could your Heart and your Liver then see your Form (outside of your body) as part of the content? So that's not possible. Could your Heart and your Liver content ever slip through the Form and view the Form from the outside? That is not possible.



**As a human being you are part of the content, and you will never be able to see the outside (the form)**

So, if you know this, you can ask yourself the question. What is outside of Form, and how did this Form come into being? So, you will never be able to know, because (as part of the content) you can never leave the content. The only thing you can study and examine as a human being and as a consciousness is everything that is within the content. And you have to deal with that.

### **Light or fire.**

We live as human beings on Earth within the darkness of the Universe. And everything we experience as light we call light. What light effects do we know on Earth? We see the Sun, the Moon, and the Stars. And we see light produced from electricity. This can be many things, streetlamps, car lamps, flashlights, lighters, burning gases, friction, etc. We call all this light because we see light in the darkness. Then ask yourself if this is really light, or if all this is fire that we perceive in the darkness?

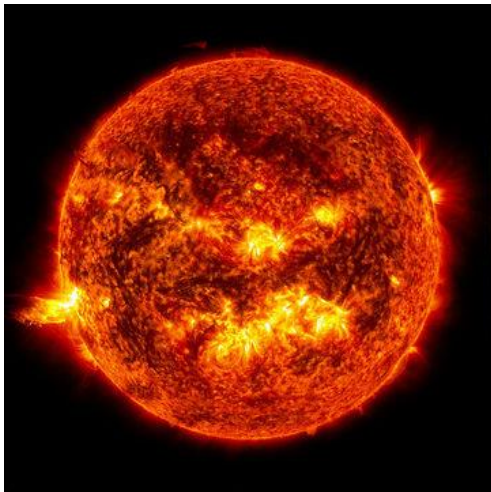

If you determine the trinity of the Sun, this is again: form, content, and mass. Now go increase the content to five (5), what do you get? Shape (round because of rotation), mass, (liquid) content, (hot) temperature, suffocation (due to the downward pressure of the Universe's mass).



The trinity of a light bulb is as the word implies. A generator creates a tension in a lead wire through a kind of friction, the voltage from the lead changes into a smaller subtle filament, which glows when the voltage is high enough. A drill bit of a drill starts glowing if the friction between the drill and, for example, the wall is large enough.

However, this is all based on fire. And we call all this light as human beings on Earth.

The question you can ask yourself here is whether this is light, I mean cosmic light? Light that we as humans have never seen in the darkness.

Darkness is the lack of visible light.

***What is the trinity of cosmic darkness?***

***Cosmic Luminescence Process.***

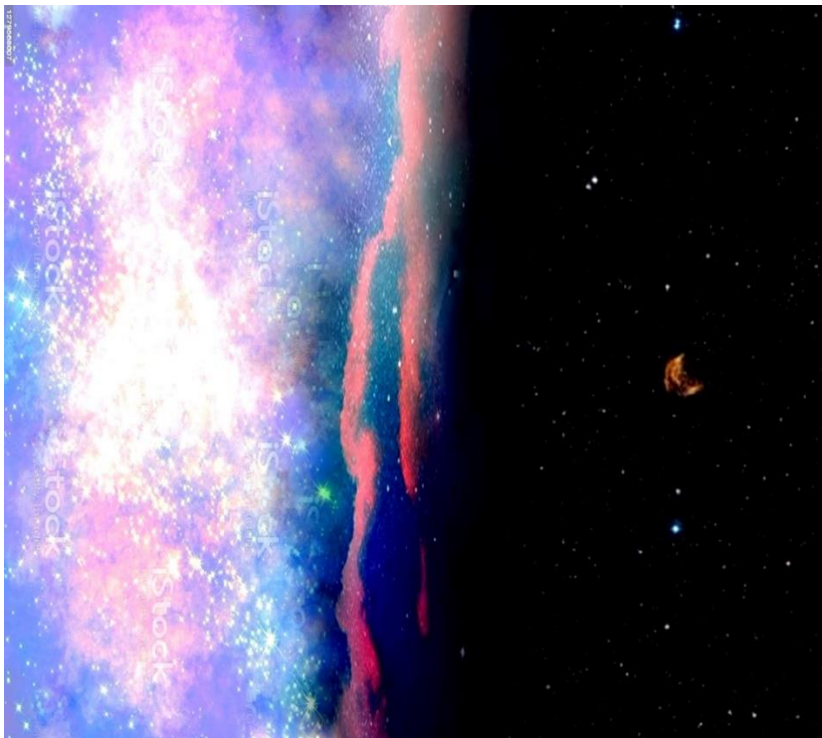

**Before forming  
a judgment, I  
suggest that you  
do some  
research first.**

***Cosmic Light / Shadow Zone / Cosmic Darkness***

## Numbers.

All numbers can be found geometrically in the Great Pyramid of Giza.

We start with the number 1. This number stands alone and therefore has no geometric value without another number being added. Suppose I add another number 2. Then  $1 + 2 = 3$ . This is the smallest geometric (existence) value.

Suppose  $1 + 1 = 2$ . Geometrically this has no meaning because they are two dashes (lines) without a substantive form.

They are 3 connected lines that make a connection (substantive form). I call this smallest geometric shape a triangle. The first three numbers are shown in a triangle.

I use the triangle  $\sqrt{1} : \sqrt{2} : \sqrt{3} (A^2+B^2=C^2)$  for this.

This triangle is the inside of the pyramid on which the theorem  $A^2+B^2=C^2$  is based, the number PI and the circumference of the circle.

The numbers 1,2 and 3 are the basis of existence and are very special.

### **How is the square root $\sqrt{2}$ constructed?**

The square root  $\sqrt{2}$  is equal to  $\sqrt{(1 + 1)^2 / (1 + 1)}$ .

This amounts to  $2^2 = 4 / 2 = 2$ . The square root of 2 =  $\sqrt{2} = 1.414$

If we project this in a triangle of  $90^\circ$ ,  $45^\circ$  and  $45^\circ$ , you can say:

C (hypotenuse) is the square root of  $(A + B)^2 / (A + B)$ .

*This comes with a warning.*

The above only applies in the ratio 1:1.



Because suppose you set A and B to 2, then you will see that it is not correct. Then it says  $(2 + 2)^2 / (2+2)$  and that makes  $\sqrt{4}$ . And  $\sqrt{4}$  is 2 and that doesn't match with the hypotenuse.

Therefore, you need to apply the following formula:  $C = \sqrt{(A + B)^2 / 2}$ .  
C is the square root of  $(A + B)^2 / 2$ .

Suppose now I have a triangle with sides A and B of 5 cm. Then the  $\sqrt{2}$  approximation is:  $(A + B)^2 / 2 = (5 + 5)^2 = 10^2 = 100 / 2 = 50 = \sqrt{50} = 7.07$  cm.

### **The same goes for the $\sqrt{3}$ calculation.**

For this, you use the ratio 1:2.  $\sqrt{3}$  is equal to the square root of  $(1 + 2)^2 / (1 + 2)$ .

The above only applies in the ratio 1:2.

Suppose I have a right triangle of  $90^\circ$ ,  $60^\circ$  and  $30^\circ$  then the ratio is A: C = 1: 2. If we now calculate the straight side B of this right triangle, then B is the square root of  $(1 + 2)^2 / (1 + 2) = 9 / 3$  is 3. The square root of 3 =  $\sqrt{3} = 1.732$  cm.

Now suppose I have a right triangle with side A = 4 cm and side C = 8 cm. Then the  $\sqrt{3}$  approximation is:  $(A + C)^2 / 3 = (4 + 8)^2 = 12^2 = 144 / 3 = 48 = \sqrt{48} = 6.92$  cm (side B).

The numbers 1, 2 and 3 are therefore always represented as a unit in the theory of existence. 1 cannot exist alone and 2 cannot exist, 3 makes the ***form, mass, and content***. The minimal existence.

### **Number 4**

The number 4 is located geometrically in the square base. The number 5 from the  $36^\circ$  angle (pentagram). The number 6 (hexagon) is on the outside (equilateral triangle).

The number 7 (septagram) from the 54° angle, the number 8 (octagram) from the base and the number 9 (enneagram) from the 40° shaft in the center. The number 0 (emptiness) is the circle itself. See figure 111.

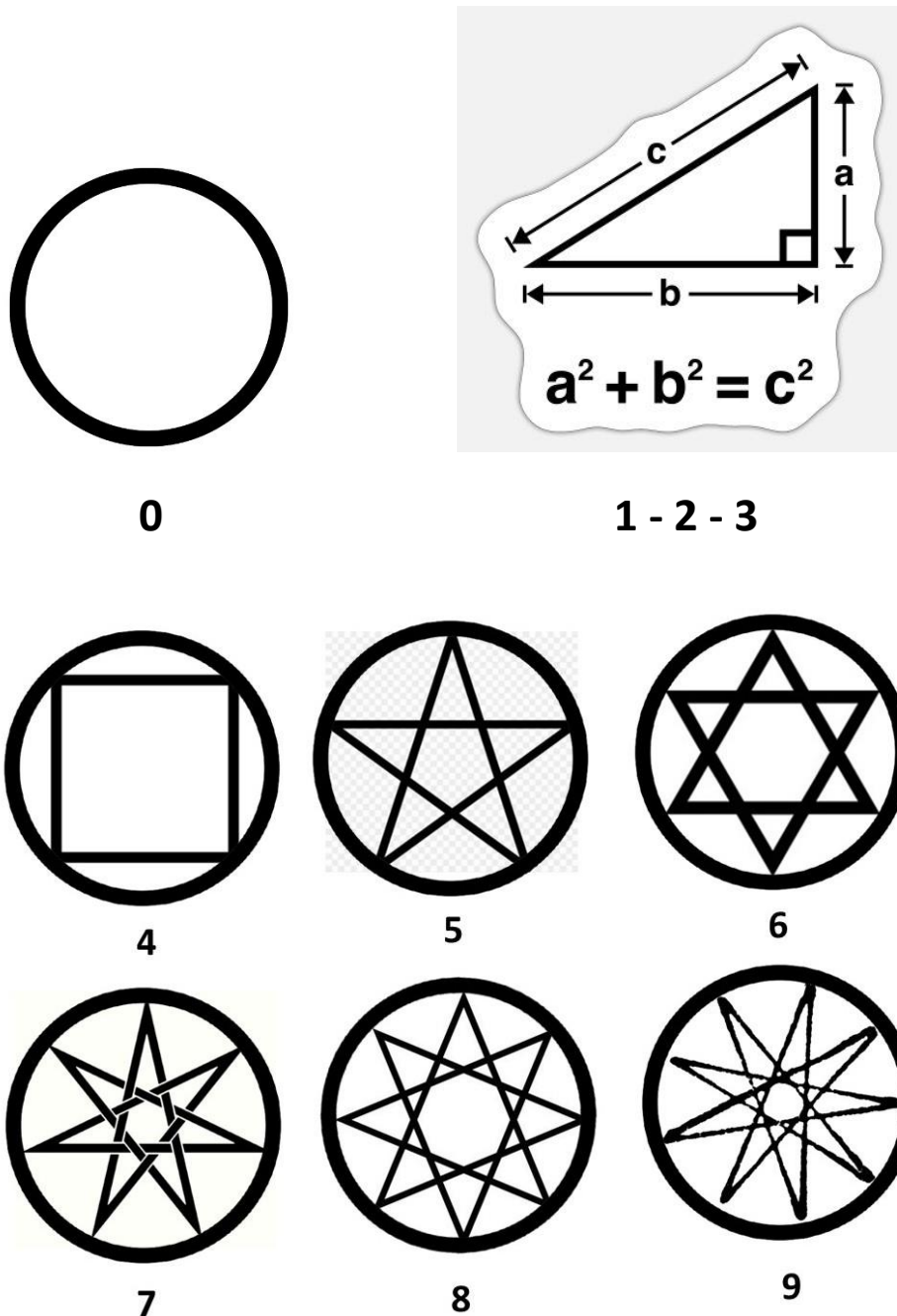

**Figure 111**

Geometrically, the numbers can be traced back to the circle of 360°.

Only the number 7 (septagram) is a special number, this does not fit within the Earth's  $360^\circ$  structure. Well within a circle of  $378^\circ$ . I will come back to that later in this book.

Thus,  $4 \times 90 = 360^\circ$ ,  $5 \times 72 = 360^\circ$ ,  $6 \times 60 = 360^\circ$ ,  $8 \times 45 = 360^\circ$ , and  $9 \times 40 = 360^\circ$ , ( $7 \times 54 = 378^\circ$ ).

Subsequently, all conceivable numbers can be traced back (calculated and drawn) to the smallest possible geometric shape, the right triangle. The result of a calculation: suppose 6834529, can be traced back geometrically to a practical right triangle shape.

Each outcome (number) of a calculation can be reduced to the theorem  $A^2+B^2=C^2$  and calculate and draw the relevant triangle.

To realize this in a simple way, you need to apply the theorem  $A^2+B^2=C^2$  slightly differently than you are used to.

Suppose you add  $3 + 4$  to 7. If we now project this in the ratio  $A^2+B^2=C^2$ , then we have a problem.  $A=3$ ,  $B=4$ , then  $C$  can never be 7. So, what we do is  $A^2+B^2= 9 + 16$  makes  $C^2 = 25$ .  $C$  is then  $\sqrt{25} = 5$ . In this way we use the theorem  $A^2+B^2=C^2$ .

I'm going to use it differently now. Suppose  $3 + 4 = 7$ . So, the result is correct. How do you calculate (and draw) the corresponding triangle? I'm not going to square the numbers.

*I determine that the numbers are squared.*

Suppose  $3 + 4 = 7$  then the corresponding triangle is  $\sqrt{3} + \sqrt{4} = \sqrt{7} = 1.73 + 2 = 2.64$ .

So, I'm not going to bring the triangle to the numbers, but the numbers to the triangle. So vice versa.

What you need to do for this is determine the quintessence of the outcome.

Suppose the result of a calculation is 6834529. Then the quintessence is  $6+8+3+4+5+2+9 = 37$ .  $A = 3 + B = 7$  makes  $C = 10$  (so these are square figures). The corresponding triangle is then  $\sqrt{3} + \sqrt{7} = \sqrt{10}$ .

Suppose the quintessence of the result has three numbers, for example 128, then  $A$  is 8 and  $B = 12 = C = 20$ . The corresponding triangle is then  $\sqrt{8} + \sqrt{12} = \sqrt{20}$ . If you get a quintessence of 3 numbers, then you are already talking about outcomes that run into the billions.

So, you can say that the quintessence of the outcome of a number calculation is inextricably linked to the geometric right triangle ratio  $A^2+B^2=C^2$ . If the 0 is in the quintessence of the suit, it stands for ten. The quintessence 30 then stands for the ratio  $A = 3$  and  $B = 10 = C = 13$  and the corresponding triangle is then  $\sqrt{3} + \sqrt{10} = \sqrt{13}$

You can now conclude that the numbers 1 - 9 and the 0 can be traced from the Great Pyramid of Giza.

### **The number 7**

As I mentioned, the number 7 is a special number. It does not fit within the Earth's  $360^\circ$  structure.  $360/7 = 51.42857142857143 \dots$



7

The number 7 (septagram  $27^\circ$ ) can be deduced within the Great Pyramid from the ground shaft of  $54^\circ$ . This will require you to adjust the circle to  $378^\circ$  ( $7 \times 54$ ). This means that you have to make a circle of  $378^\circ$  (dividing the circle into 378 mm). You can read how to do this in a simple way in the summary of the booklet '*Trigonometric change*' (Dutch language).

### **The zero**

The 0 (zero) has no value by itself. It is not a value number like the other numbers. The 0 (zero) is a position number that placed next to another (value) number increases a number cycle, 10, 30, 500 etc.

0 parts are no parts.

Everything starts at 1 and everything that exists is 1. So, the number 1 is unique in its existence.  $1 + 1 = 2$ . In practice this means that you add two unique 1 parts. Suppose you have a man named John and another man named William. So, if we add up these men, we have 2 men. What we must remember now is that the men are each unique and no two are alike in the Universe. Every man (and woman) has a unique characteristic, a unique fingerprint, and a unique DNA. So, we cluster arithmetic parts that are always unique 1 and will always remain unique 1. So, 2 apples are not equal to each other, there is no such thing. Each apple is unique and different from each other. Numbers have an abstract meaning and if we are aware of that and remain aware of it then it is fine. 0 is therefore nothing in itself. 0 does not exist. 0 apples and 0 pears do not exist. 0 as position number 10, 20, 50, 1000 etc. increases the value of the numbers 1 - 9.

### **How we misdirect our unconscious**

A PC (computer) is a device that can automatically process data.

In order to process this data, the computer uses 2 types of electrical voltage: a high voltage (written as the number 1) and a low voltage (written as 0). The computer can 'read' a number of high and low voltages in succession.

A row of ones and zeros is seen as a number, an assignment or an outcome.

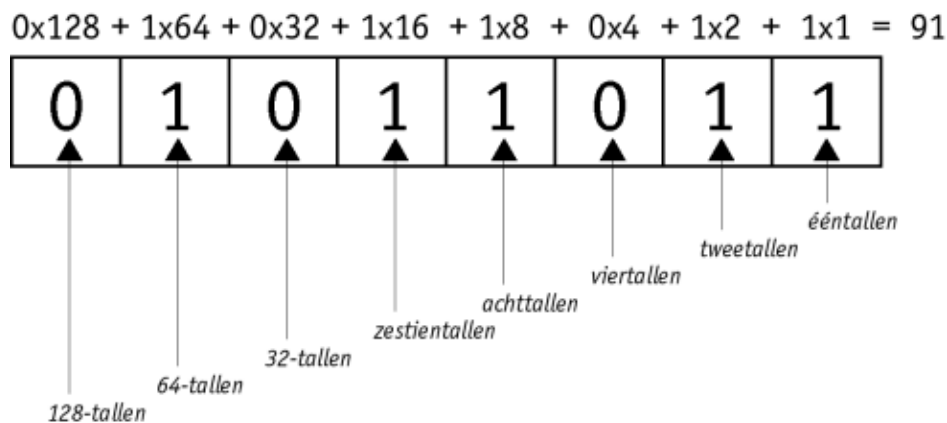

What we have unconsciously done in our human mind has assigned the zero (0) a value. We have raised the 0 to a value number over time. And that is impossible. The zero has no value. 10 is not 0 and 30 and 40 neither (10x1=10 and 0x1=nothing).

If you use 0 as code language (binary system) then 0 is a number, as is 1 also the case. This allows the subconscious of the human being to see the 0 as a value number. And therefore, assume that one can go from 0 to 1. **From nothing to something.** And that is impossible. In science we look for the nothingness (the beginning) the 0, which does not exist practically and cannot exist. We look for the origin from nothing, something that does not exist and cannot and has not existed. Simple because the 0 (non-existence) does not exist in practice. It is an abstract figure created in the mind of man. Everything starts with 1 (existence). That's the start. So, if we want to look for the origin (beginning) of the Universe, that is wasted energy because you will never encounter it.

It is more often scientifically more important to investigate what is there rather than what is not there and has never been.

You can refute the statement 'there must be a beginning' with the statement 'there is eternity' (eternal existence).

Whether we can comprehend that depends on our consciousness.

Everything is 1 and 1 is everything. Are we going to cut a cake imaginary into pieces, then wonder when you cut off the last piece that can no longer be divided?



The numbers speak for themselves. If I subtract from 1, I will never get a starting (end) number. The same applies if I add to 1. I will never get a final number. I can count forever.

This means that there is no starting number and no ending number. Projecting this to the Universe, it is logical and understandable that there is no beginning and no end in human consciousness.

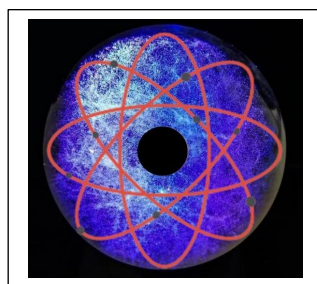

**You are a part of the contents of the Universe, and you go round and round and never get out.**

If I fly in a fixed direction with a rocket forever, do you wonder when will I come across something that doesn't exist?

## Cumulative Number Sequence.

The number sequences below show how perfectly numbers are designed and how they are geometrically shaped.

In the series of ***cumulative factor 4*** (see figure 112), each number is used 1 time in the addition.  $1+2=3$ ,  $3+4=7$ ,  $5+6=11$ , etc. (uneven outcomes) You see how the cumulative factor of 4 increases the results in equal steps of 4. At the same time, each number below each other is increased by  $\sqrt{4}$ . 1-3, 2-4.

Then each sum is a squaring of a corresponding triangle  $A^2+B^2=C^2$ :  
 $1+2=3$  ( $\sqrt{1}+\sqrt{2}=\sqrt{3}$ ),  $3+4=7$  ( $\sqrt{3}+\sqrt{4}=\sqrt{7}$ ),  $5+6=11$  ( $\sqrt{5}+\sqrt{6}=\sqrt{11}$ ).

How do you know which number belongs in the cumulative series 4?

How do you know which number belongs in the cumulative series 4?

If you look at the sequence, you will see that every last number of the outcome ends in the number 3.7 and 1.5.9 and this comes back every time (above the number 19).

A number must therefore end with one of the aforementioned final numbers. Let's take the number 419 as an example. How do you know whether this number belongs in the series and how many times it has been increased by the cumulative factor of 4. You do this as follows. You subtract the result of the first sum of the number ( $419-3=416$ ). Then divide 416 by factor 4 ( $416/4=104$ ). You now know that the number 419 has been increased by a factor of 4, 104 times.

Suppose you take the number 384.  $384-3=381$ .  $381/4=95.25$ . This is therefore not a fixed number and does not fit in the series. So, you can count to infinity. The number 0 in itself does not exist, which is why it can never be the beginning. 1 is the start.



With the series *cumulative factor 9* (see figure 112) we leave the geometric triangle shape ( $\sqrt{1}+\sqrt{2}=\sqrt{3}$ ), and we move on to the calculation method.

Each number is also used here only once and (equal to a factor of 4) follows each other.

We start by adding  $1+2+3 = 6$ . Then we add  $4+5+6 = 15$ . And so on. The series shows that each outcome is increased by the cumulative factor of 9. (6,15,24,33, etc.)

At the same time, each number below each other is increased by  $\sqrt{9}$ .  
4-7, 5-8, 6-9.

And what is so unique about this series. The quintessence of the outcome is always and everywhere **6**.  $22+23+24 = 69$  ( $6+9=15$ .  $1+5 = 6$ )

How do you know if a number falls within the range?

So, if the quintessence of the number is **6**.

Suppose we take the number 528.  $5+2+8 = 15$ .  $1+5 = 6$ .

In that case we subtract  $528-6=522$ .  $522/9=58$ . So, the number 528 has been increased 58 times by a factor of 9.

Suppose we take the number 426.  $4+2+6=12$ .  $1+2=3$  (so it's not 6). Then you get  $426-6=420$ .  $420/9=46.66$ . This is therefore not a fixed number and does not fit in the series.

You can now count again to infinity.

If you divide the result by 3, you always have the middle number.

Figure 112 shows the starting numbers of the series.

You see how unique the numbers are, both geometrically and arithmetically.

## Number sequences.

### Cumulative factor 4

### Cumulative factor 9

$1+2 = 3$	$1+2+3 = 6$
$3+4 = 7$	$4+5+6 = 15$
$5+6 = 11$	$7+8+9 = 24$
$7+8 = 15$	$10+11+12 = 33$
$9+10 = 19$	$13+14+15 = 42$
$11+12 = 23$	$16+17+18 = 51$
$13+14 = 27$	$19+20+21 = 60$
$15+16 = 31$	$22+23+24 = 69$
$17+18 = 35$	$25+26+27 = 78$
$19+20 = 39$	$28+29+30 = 87$
$21+22 = 43$	$31+32+33 = 96$
$23+24 = 47$	$34+35+36 = 105$
$25+26 = 51$	$37+38+39 = 114$
$27+28 = 55$	$40+41+42 = 123$
$29+30 = 59$	$43+44+45 = 132$
$31+32 = 63$	$46+47+48 = 141$
$33+34 = 67$	$49+50+51 = 150$
$\dots + \dots = \dots$	$\dots + \dots + \dots = \dots$

**Figure 112**

## Geometric number sequences.

### Squared Number Sequence

$$1 + 2 = 3 \text{ (triangle } \sqrt{1} + \sqrt{2} = \sqrt{3}\text{)}$$

$$3 + 4 = 7 \text{ (triangle } \sqrt{3} + \sqrt{4} = \sqrt{7}\text{)}$$

$$5 + 6 = 11 \text{ (triangle } \sqrt{5} + \sqrt{6} = \sqrt{11}\text{)}$$

$$7 + 8 = 15$$

$$9 + 10 = 19$$

$$11 + 12 = 23$$

$$13 + 14 = 27$$

$$15 + 16 = 31$$

$$17 + 18 = 35$$

$$19 + 20 = 39$$

$$21 + 22 = 43$$

$$23 + 24 = 47$$

$$25 + 26 = 51$$

$$27 + 28 = 55$$

$$29 + 30 = 59$$

$$31 + 32 = 63 \text{ (triangle } \sqrt{31} + \sqrt{32} = \sqrt{63}\text{)}$$

$$33 + 34 = 67 \text{ (triangle } \sqrt{33} + \sqrt{34} = \sqrt{67}\text{)}$$

$$\dots + \dots = \dots$$

**Random squared numbers.**

$6 + 9 = 15$  (triangle  $\sqrt{6} + \sqrt{9} = \sqrt{15}$ )

$16 + 28 = 44$  (triangle  $\sqrt{16} + \sqrt{28} = \sqrt{44}$ )

$23 + 34 = 57$  (triangle  $\sqrt{23} + \sqrt{34} = \sqrt{57}$ )

**Squared Number Sequence (Theodorus) Golden Spiral**

$1 + 1 = 2$  (triangle  $\sqrt{1} + \sqrt{1} = \sqrt{2}$ )

$1 + 2 = 3$  (triangle  $\sqrt{1} + \sqrt{2} = \sqrt{3}$ )

$1 + 3 = 4$  (triangle  $\sqrt{1} + \sqrt{3} = \sqrt{4}$ )

$1 + 4 = 5$

$1 + 5 = 6$

$1 + 6 = 7$

$1 + 7 = 8$

$1 + 8 = 9$

$1 + 9 = 10$

$1 + 10 = 11$

$1 + 11 = 12$

$1 + 12 = 13$  (triangle  $\sqrt{1} + \sqrt{12} = \sqrt{13}$ )

$1 + 13 = 14$  (triangle  $\sqrt{1} + \sqrt{13} = \sqrt{14}$ )

Etc.

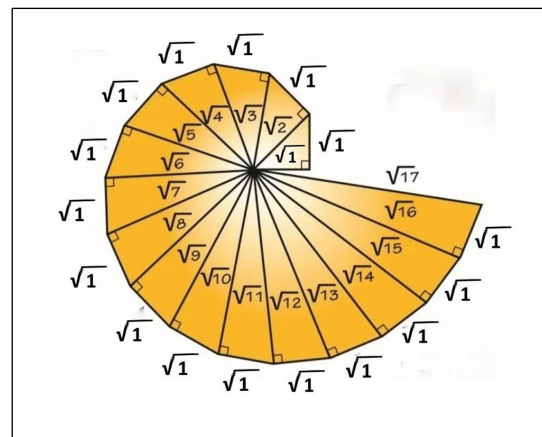

## Final Summary

This booklet is intended for anyone who wishes to acquire the knowledge described herein.

*Everyone is free to (practically) use everything written in this booklet and to transfer the knowledge, provided that the source is cited (author WvEs).*



*Geometry is the  
structure of the  
Universe and man  
determines his shape.*

October 2022

ISBN: 978-90-9036723-1